

Features

- Brass body construction for general atmospheres; stainless steel for corrosive atmospheres
- Can be internally piloted, or externally piloted to convert valve to zero minimum operation by flipping a gasket
- When externally piloted, loss of electrical power or auxiliary air exhausts air from the actuator and shifts process valve to its original position
- When internally piloted, loss of electric power returns the valve to its original position
- Also available with Low Power or Intrinsically Safe solenoids. See *Special Service Valve Section*

Construction

| Valve Parts in Contact with Fluids | | |
|------------------------------------|---------------------|---------------------|
| Body | Brass | 316 Stainless Steel |
| End Plate | 304 Stainless Steel | 316 Stainless Steel |
| Seals and Discs | Low Temp NBR | |
| Core Tube | 305 Stainless Steel | |
| Core Guide | CA | |
| Shading Coil | Copper | Silver |

Electrical

| Standard Coil and Class of Insulation | Watt Rating and Power Consumption | | | | Spare Coil Part Number | | | | | |
|---------------------------------------|-----------------------------------|-------|------------|-----------|------------------------|--------|---------------------|--------|---------------------|--------|
| | DC Watts | AC | | | General Purpose | | Explosionproof (EF) | | Explosionproof (EV) | |
| | | Watts | VA Holding | VA Inrush | AC | DC | AC | DC | AC | DC |
| F | 11.6 | 10.1 | 25 | 50 | 238610 | 238710 | 272614 | 238714 | 274614 | 274714 |

Standard Voltages: 24, 120, 240, 480 volts AC, 60 Hz (or 110, 220 volts, AC, 50 Hz).
 6, 12, 24, 120, 240 volts DC. Must be specified when ordering.
 Other voltages are available when required.

Solenoid Enclosures

Brass Body Valves:

Standard: Watertight, Types 1, 2, 3, 3S, 4, and 4X.

Optional: Explosionproof and Watertight, Types 3, 3S, 4, 4X, 6, 6P, 7, and 9. (Add prefix "EF" to catalog number.)

Stainless Steel Valves:

Standard: Explosionproof and Watertight, Types 3, 3S, 4, 4X, 6, 6P, 7, and 9.

See *Optional Features Section* for other available options.

Installation

All valves may be mounted in any position.
 316 Stainless Steel mounting brackets available from ASCO. Add suffix "MB".

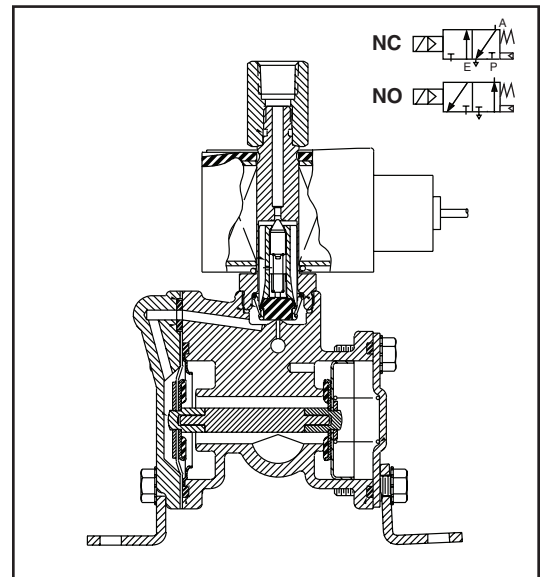
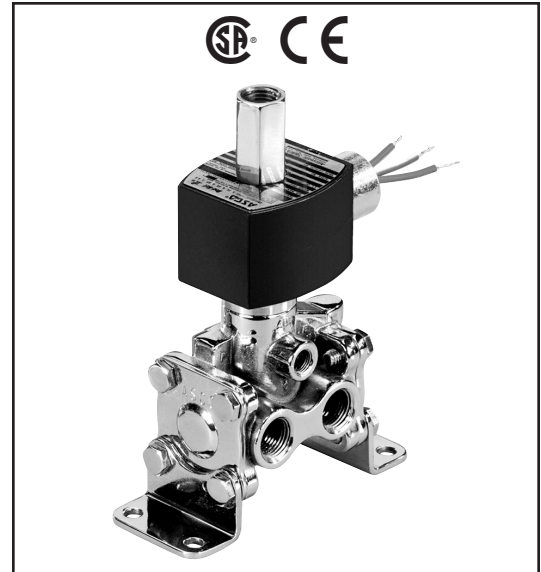

3-WAY

Nominal Ambient Temp. Ranges

Standard Construction:

AC: -20°F to 125°F (-28°C to 52°C)

DC: -20°F to 104°F (-28°C to 40°C)

Approvals

Valves with prefix "EF" or "EV"; UL approved and CSA certified solenoid. Meets applicable CE directives.

SIL 3 capable per IEC 61508 on normally closed const. Third party certification provided by EXIDA.

Specifications (English units)

| Pipe Size (in) | Orifice Size (in) | CV Flow Factor | Min. | Max. Air Press. (psi) | | Catalog Number | | Const. Ref. | Max. Fluid Temp. °F | | Watt Rating/ Class of Coil Insulation | |
|---|-------------------|----------------|------|-----------------------|-----|----------------|-----------------|-------------|---------------------|-----|---------------------------------------|--------|
| | | | | AC | DC | Brass Body | Stainless Steel | | AC | DC | AC | DC |
| NORMALLY CLOSED (Closed when de-energized) ① – PFD _{AVG} = 9.30 x 10 ⁻⁴ | | | | | | | | | | | | |
| 1/4 | 5/16 | 1.5 | ② | 150 | 120 | 8316G001 | EV8316G081 | 1 | 180 | 120 | 10.1/F | 11.6/F |
| 3/8 | 5/16 | 1.5 | ② | 150 | 120 | 8316G002 | EV8316G082 | 1 | 180 | 120 | 10.1/F | 11.6/F |
| 3/8 | 5/8 | 4 | ② | 150 | 120 | 8316G003 | - | 2 | 180 | 120 | 10.1/F | 11.6/F |
| 1/2 | 5/8 | 4 | ② | 150 | 120 | 8316G004 | EV8316G084 | 2 | 180 | 120 | 10.1/F | 11.6/F |

① Consult factory for Normally Open. ② Zero minimum when valve selection gasket is in external position and proper auxiliary air pressure is applied. See graph below for pilot line pressure vs. mainline pressure. Minimum 15 psi (1 bar) operating pressure differential when selection gasket is in the internal position.

IMPORTANT: Internal mode Minimum Operating Pressure Differential must be maintained between the pressure and exhaust ports. Supply and exhaust piping must be full area and unrestricted. ASCO flow controls and similar components must be installed in the cylinder lines only.

Specifications (Metric units)

| Pipe Size (in) | Orifice Size (mm) | Kv Flow Factor (m3/h) | Min. | Max. Air Press. (bar) | | Catalog Number | | Const. Ref. | Max. Fluid Temp. °C | | Watt Rating/ Class of Coil Insulation | |
|---|-------------------|-----------------------|------|-----------------------|----|----------------|-----------------|-------------|---------------------|----|---------------------------------------|--------|
| | | | | AC | DC | Brass Body | Stainless Steel | | AC | DC | AC | DC |
| NORMALLY CLOSED (Closed when de-energized) ① – PFD _{AVG} = 9.30 x 10 ⁻⁴ | | | | | | | | | | | | |
| 1/4 | 8 | 1.3 | ② | 10 | 8 | 8316G001 | EV8316G081 | 1 | 82 | 49 | 10.1/F | 11.6/F |
| 3/8 | 8 | 1.3 | ② | 10 | 8 | 8316G002 | EV8316G082 | 1 | 82 | 49 | 10.1/F | 11.6/F |
| 3/8 | 16 | 3.4 | ② | 10 | 8 | 8316G003 | - | 2 | 82 | 49 | 10.1/F | 11.6/F |
| 1/2 | 16 | 3.4 | ② | 10 | 8 | 8316G004 | EV8316G084 | 2 | 82 | 49 | 10.1/F | 11.6/F |

Dimensions: inches (mm)

MAINLINE PRESSURE vs. PILOT LINE PRESSURE WHEN SELECTION GASKET IS IN EXTERNAL POSITION

1/4 NPT
1/2 NPT
4.68 [119]
5.48 [139]
2.69 [68]
1.27 [32]
NPT 3 PLACES

Const. Ref. 1
4.67 [119]
4.05 [103]
1.96 [50]
2.06 [52]
1.25 [32]
1.28 [33]
OPTIONAL MOUNTING BRACKET WITH Ø.28 [Ø7] HOLES 4 PLACES

Const. Ref. 2
1.95 [50]
4.93 [125]
6.35 [161]
2.93 [75]
1.41 [36]
2.72 [69]

1/8 NPT AUX PRESS
NPT 3 PLACES
1.19 [30]
1.32 [34]
1.24 [31]
3.59 [91]
4.04 [103]

INTERNAL PILOTING MODE FLOW DIAGRAMS

| De-Energized | Energized |
|--------------|-----------|
| | |

EXTERNAL PILOTING MODE FLOW DIAGRAMS

| De-Energized with Auxiliary Pressure Applied | Energized with Auxiliary Pressure Applied |
|--|---|
| | |