

Features

- Molded one-piece solenoid with highly efficient solenoid cartridge and 0.55 W low wattage coil
- Standard ambient temperature of 149°F (65°C)
- Optional 176°F (80°C) high ambient temperature version
- Designed for use in automation of plant control systems to provide:
 - PLC and DCS® compatibility for BUS network and traditional wiring
 - Reduced temperature rise
 - Increase battery life
 - Reduce wiring cost
 - Energy savings
- Wide selection includes 2/2, 3/2 normally closed (including Quick Exhaust), 3/2 universal, 4/2, 5/2, & 5/3

Construction

Valve Parts in Contact with Fluids			
Body	Aluminum	Brass	Stainless Steel
Seals and Discs	PUR, NBR		
Sleeve	304L Stainless Steel		
Core and Plugnut	430F Stainless Steel		
Core Springs	302 Stainless Steel		
Pilot Seat Insert (Series 8316 & 8344 only)	POM		
Rider Rings	PTFE		
Spring Retainer	POM		

Electrical

Description	Wattage	Max. Ambient Temp.	T Code	Insulation Class	Prefix
Standard Ambient Version	.55 W	149°F (65°C)	T6	F	-
High Ambient Version	.70 W	176°F (80°C)	T6	H	HT
Surge Suppression Version	.75 W	149°F (65°C)	T6	F	MF

Ⓛ **IMPORTANT:** Supervisory and leakage current above the drop out current listed will cause improper operation. Consult your local ASCO sales office for additional assistance.

Description	Wattage	Voltage (DC)	Min. Pull In (mA)	Drop Out (mA) Ⓛ	Coil Resistance @68°F (20°C) (ohms)
Standard Ambient Version	.55W	12V	34	3.63	255
		24V	17	1.80	1025
		48V	8.5	0.91	4080
		125V Ⓜ	3.2	0.34	27,400
High Ambient Version	.70W	12V	37	3.97	206
		24V	19	1.98	830
		48V	9.7	1.03	3185
		125V Ⓜ	3.7	0.39	21150
Surge Suppression Version (Available only in Explosionproof version)	.75W	12V	41	4.41	165 Ⓜ
		24V	19	1.98	830 Ⓜ
		48V	9.7	1.03	3185 Ⓜ
		125V Ⓜ	3.7	0.39	21150 Ⓜ

Note: Ⓜ Not for battery applications. Ⓜ Surge suppression contains diode bridge.

24VDC Spare Coil P/N	Standard Ambient Temp. Version	High Ambient Temp. Version
General Purpose	238710-913-D*	238910-906-D*
Explosion Proof	238714-914-D*	238914-906-D*
Explosion Proof, Corrosion Resistant	274714-909-D*	274914-906-D*
Explosion Proof, Surge Suppression	276006-206-D*	Not Available
Explosion Proof, Corrosion Resistant, Surge Suppression	276007-206-D*	Not Available

Note: For 12VDC, 48VDC and 125VDC coil PN consult factory

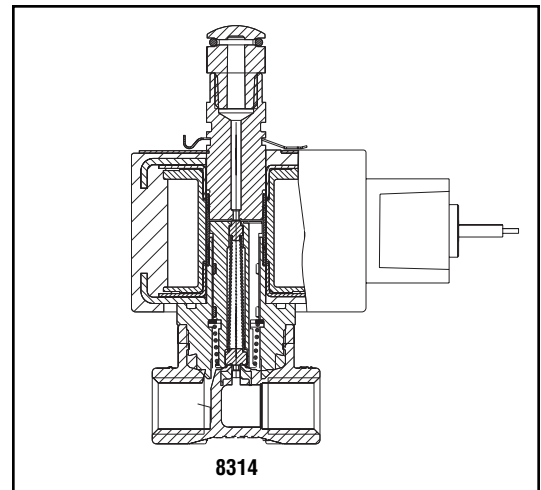
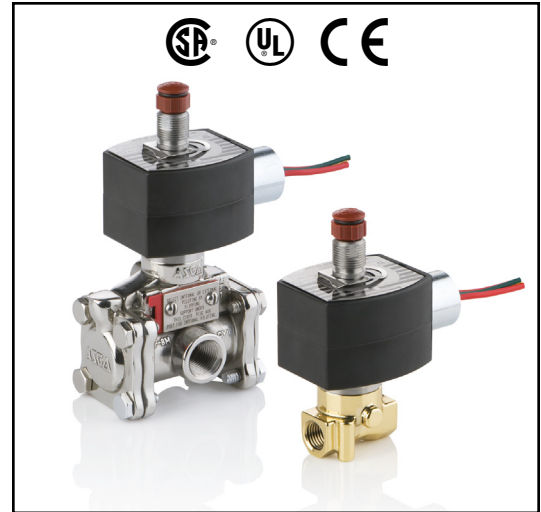

SPECIAL SERVICE PILOT

Ordering

Normal Ambient Version: EV8551H322 24VDC
High Ambient Version: EF HT 8316H301 24VDC
Surge Suppression Version: EV MF 8314H301 24VDC

Solenoid Enclosures

Standard: Watertight, Types 1, 2, 3, 3S, 4, and 4X.
Optional: Explosionproof and Watertight, Types 3, 3S, 4, 4X, 6, 6P, 7, and 9.
 (To order, add prefix "EF" to catalog number. For explosionproof with 316 Stainless Steel hub and trim, specify prefix "EV".) Surge suppression coils also available "MF" prefix.

See *Optional Features Section* for other available options.

Approvals

UL & CSA Approved for Class I Div. 1 Locations & Class I Div. 2 Non-Incendive Solenoid for Hazardous Locations. UL Listed General Purpose Valves. Meets applicable CE directives. SIL 3 capable per IEC 61508 on 8314, 8316, 8551, and 8553 const. Third party certification provided by EXIDA. Refer to *Engineering Section* for details.

Nominal Ambient Temp. Ranges

Series	Body Material	Normal Temperature Range	High Ambient Temp Version
8553	Stainless Steel	-40°F to 140°F (-40°C to 60°C)	Not Available
8551	Brass	-40°F to 140°F (-40°C to 60°C)	
8553	Aluminum	-13°F to 140°F (-25°C to 60°C)	
8551		5°F to 140°F (-15°C to 60°C)	
8551	Stainless Steel	-40°F to 149°F (-40°C to 65°C)	Low Limit is the same as Normal Temperature Ratings, but High Limit is 176°F (80°C)
8262	Brass / Stainless Steel	-40°F to 149°F (-40°C to 65°C)	
8314		-40°F to 149°F (-40°C to 65°C)	
8317		-40°F to 149°F (-40°C to 65°C)	
8316*		-20°F to 149°F (-29°C to 65°C)	
8223	Brass only	-4°F to 149°F (-20°C to 65°C)	
8344		-4°F to 149°F (-20°C to 65°C)	
8316H334		-4°F to 149°F (-20°C to 65°C)	

*Does not include 8316H334; Includes 8316J374. **Note:** 8553 not available in brass

Important

These solenoid valves are intended for use on clean dry air or inert gas, filtered to 40 micrometres or better. The dew point of the media should be at least 10°C (18° F) below the minimum temperature to which any portion of the clean air/inert gas system could be exposed to prevent freezing. If lubricated air is used, the lubricants must be compatible with Nitrile elastomers. Diester oils may cause operational problems. Instrument air in compliance with ANSI/ISA Standard 7.0.01-1996 exceeds the above requirements and is, therefore, an acceptable media for these valves.

Specifications (English units)

Pipe Size (in)	Orifice Size (in)	Cv Flow Factor		Operating Pressure Differential (psi)		Max. Fluid and Ambient Temp. °F	Brass Body		Stainless Steel Body	
				Air-Inert Gas			Catalog Number	Const. Ref.	Catalog Number	Const. Ref.
		Pressure to Cylinder	Cylinder to Exhaust	Min.	Max.					
2/2 VALVES, NORMALLY CLOSED, with NBR Disc										
1/4	1/16	.06		0	130	149	8262H320 ††	1	8262H386 ††	1
3/8	5/16	1.5		10	130	149	8223H323	2	-	-
1/2	3/8	3.2		25	130	149	8223H303	3	8223H310 ⑥	3
3/2 VALVES, UNIVERSAL OPERATION (Normally Closed or Normally Open) with NBR Disc – SIL 3 Capable, Certified by Exida ⑩ ⑪										
1/4	1/20	.06	.06	0	130/105 ⑦	149	8314H300 ††	4	8314H301 ††	5
3/2 VALVES, NORMALLY CLOSED (Closed when de-energized) with NBR Disc – SIL 3 Capable, Certified by Exida ⑩										
1/4	5/16	1.5	1.5	⑤	130	149	8316H301 ③	6	EV8316H381 ⑥	6
3/8	5/16	1.8	1.8	⑤	130	149	8316H302 ③	6	EV8316H382 ⑥	6
3/8	5/8	4	4	⑤	130	149	8316H303 ③	6	-	-
1/2	5/8	4	4	⑤	130	149	8316H304 ③	6	EV8316H384 ⑥	6
3/4	11/16	5.5	5.5	10	130	149	8316J374 ③	7	-	-
1	1	13	13	10	130	149	8316H334 ③⑧	8	-	-
3/2 VALVES, UNIVERSAL (Normally Closed or Normally Open) "Quick Exhaust" with NBR Diaphragm and NBR Disc										
1/4	②	.06	.73	5	130	149	8317H307 ①	9	8317H308 ①⑥	10
4/2 VALVES, Brass Body with NBR Disc										
Pipe Size (in)	Orifice Size (in)	Cv Flow Factor		Operating Pressure Differential (psi)		Max. Fluid and Ambient Temp. °F	Single Solenoid		Dual Solenoid	
				Air-Inert Gas			Catalog Number	Const. Ref.	Catalog Number	Const. Ref.
		Pressure to Cylinder	Cylinder to Exhaust	Min.	Max.					
1/4	1/4	.80	1	10	130	149	8344H370 ①③	11	8344H344 ③†	12
3/8	3/8	1.5	2.2	10	130	149	8344H372 ①③	13	8344H380 ③†	14
1/2	3/8	1.5	2.2	10	130	149	8344H374 ①③	13	8344H382 ③†	14
3/4	3/4	5.2	5.6	10	130	149	8344H376 ①③	15	8344H354 ③†	16
1	3/4	5.2	5.6	10	130	149	8344H378 ①③	15	8344H356 ③†	16

① There are two exhaust flows in the exhaust mode (pilot and main). The pilot exhaust must be connected to the main exhaust when the air or inert gas cannot be exhausted to atmosphere.

② For "Quick Exhaust" valves, pressure port is 1/16", exhaust port is 1/4".

③ **IMPORTANT:** A Minimum Operating Pressure Differential must be maintained between the pressure and exhaust ports. Supply and exhaust piping must be full area, unrestricted. ASCO flow controls and other similar components must be installed in the cylinder lines only.

④ Zero minimum when valve selection gasket is in external position and proper auxiliary air pressure is applied. Minimum 15 psi Operating Pressure Differential when selection gasket is in the internal position.

⑤ Can be used for **dry** natural gas service (no agency approvals) with the EF or EV prefix without manual operator.

⑦ Normally closed = 130 psi / Normally open = 105 psi.

⑧ Solenoid only approvals with EF or EV prefix, no approvals with general purpose coil (no prefix).

⑨ Safety manual and FMEDA (Failure Modes Effects and Diagnostic Analysis) report available.

⑩ SIL 3 Capable, Certified by Exida, only valid when used as Normally Closed.

† Dual solenoid 8344 requires minimum pressure of 20 psi. Single solenoid version has 10 psi minimum pressure requirement.

†† UL/CSA approved for use with dry natural gas or propane gas with EF or EV prefix without manual operator.



2/2•3/2•4/2
5/2•5/3
SERIES
Low
Power

Specifications (English units)

Body Material	Pipe Size (in)	Orifice Size (in)	Cv Flow Factor	Single Solenoid – SIL 3 Capable, Certified by Exida ⑨					Dual Solenoid				
				Operating Pressure Differential (psi)		Max. Fluid Temp. °F	Catalog Number	Const. Ref.	Operating Pressure Differential (psi)		Max. Fluid Temp. °F	Catalog Number	Const. Ref.
				Air-Inert Gas					Air-Inert Gas				
				Min.	Max.	Min.	Max.						
3/2, 5/2, 5/3 VALVES, with NBR and PUR Seals													
Aluminum 3/2	1/4	1/4	.86	35	130	149	8551H305 ⑧	17	30	130	149	8551H306 ⑧	17
Aluminum 5/2							8551H317 ⑧	18				8551H318 ⑧	18
Aluminum 5/3 Center Closed							-	18				8551H367 ⑧	18
Aluminum 5/3 Center Open							-	18				8551H368 ⑧	18
Brass 3/2							EF8551H307 ②⑧	17				EF8551H308 ②⑧	17
Brass 5/2							EF8551H319 ②⑧	18				EF8551H320 ②⑧	18
316L Stainless Steel 3/2							EV8551H313 ③⑥⑧	17				EV8551H314 ③⑥⑧	17
316L Stainless Steel 5/2							EV8551H321 ③⑥	18				EV8551H322 ③⑥	18
Aluminum 3/2	1/2	1/2	3.7	35	130	149	8553H305 ⑧	17	30	130	149	8553H306 ⑧	17
Aluminum 5/2							8553H317 ⑧	18				8553H318 ⑧	18
316L Stainless Steel 3/2							EV8553H313 ③⑥⑧	17				EV8553H314 ③⑥⑧	17
316L Stainless Steel 5/2							EV8553H321 ③⑥⑧	18				EV8553H322 ③⑥⑧	18

② Brass construction supplied standard with EF solenoid.
 ③ Stainless steel construction supplied standard with EV solenoid.
 ⑥ Can be used for **dry** natural gas service (no agency approvals) with the EF or EV prefix without manual operator.
 ⑧ Solenoid only approvals with EF or EV prefix, no approvals with (no prefix) general purpose coil.
 ⑨ Safety manual and FMEDA (Failure Modes Effects and Diagnostic Analysis) report available.

SPECIAL SERVICE PILOT

Body Material	Pipe Size (in)	Orifice Size (in)	Cv Flow Factor	Single Solenoid – SIL 3 Capable, Certified by Exida ⑨					Dual Solenoid				
				Operating Pressure Differential (psi)		Max. Fluid Temp. °F	Catalog Number	Const. Ref.	Operating Pressure Differential (psi)		Max. Fluid Temp. °F	Catalog Number	Const. Ref.
				Air-Inert Gas					Air-Inert Gas				
				Min.	Max.	Min.	Max.						
3/2, 5/2, 5/3 VALVES, with NBR and PUR Seals, NAMUR Mount													
Aluminum 3/2, 5/2	1/4	1/4	.86	35	130	149	8551H301 ①	19	30	130	149	8551H302 ①	19
Aluminum 5/3 Center Closed							-	-				8551H365 ⑧	20
Aluminum 5/3 Center Open							-	-				8551H366 ⑧	20
Brass 3/2, 5/2							EF8551H303 ①②⑧	19				EF8551H304 ①②⑧	19
316L Stainless Steel 3/2, 5/2							EV8551H309 ③⑥	20				EV8551H310 ③⑥	20
Aluminum 3/2, 5/2	1/2	1/2	3.7	35	130	149	8553H301 ⑧	20	30	130	149	8553H302 ⑧	20
316L Stainless Steel 3/2, 5/2							EV8553H309 ③⑥⑧	20				EV8553H310 ③⑥⑧	20

① 1/8" NPT exhaust for 1/4" aluminum and brass.
 ② Brass construction supplied standard with EF solenoid.
 ③ Stainless steel construction supplied standard with EV solenoid.
 ⑥ Can be used for **dry** natural gas service (no agency approvals) with the EF or EV prefix without manual operator.
 ⑧ Solenoid only approvals with EF or EV prefix, no approvals with (no prefix) general purpose coil.
 ⑨ Safety manual and FMEDA (Failure Modes Effects and Diagnostic Analysis) report available.

Specifications (Metric units)

Pipe Size (in)	Orifice Size (mm)	Kv Flow Factor (m ³ /h)		Operating Pressure Differential (bar)		Max. Fluid and Ambient Temp. °C	Brass Body		Stainless Steel Body	
				Air-Inert Gas			Catalog Number	Const. Ref.	Catalog Number	Const. Ref.
		Pressure to Cylinder	Cylinder to Exhaust	Min.	Max.					
2/2 VALVES, NORMALLY CLOSED, with NBR Disc										
1/4	2	.07		0	9	65	8262H320 ††	1	8262H386 ††	1
3/8	8	1.3		0.7	9	65	8223H323	2	-	-
1/2	10	2.7		1.7	9	65	8223H303	3	8223H310 ⑥	3
3/2 VALVES, UNIVERSAL OPERATION (Normally Closed or Normally Open) with NBR Disc – SIL 3 Capable, Certified by Exida ⑩ ⑪										
1/4	1.3	.05	.05	0	9/7 ⑦	65	8314H300 ††	4	8314H301 ††	5
3/2 VALVES, NORMALLY CLOSED (Closed when de-energized) with NBR Disc – SIL 3 Capable, Certified by Exida ⑩										
1/4	8	1.3	1.3	⑤	9	65	8316H301 ③	6	EV8316H381 ⑥	6
3/8	8	1.6	1.6	⑤	9	65	8316H302 ③	6	EV8316H382 ⑥	6
3/8	16	3.5	3.5	⑤	9	65	8316H303 ③	6	-	-
1/2	16	3.5	3.5	⑤	9	65	8316H304 ③	6	EV8316H384 ⑥	6
3/4	17	4.7	4.7	0.7	9	65	8316J374 ③	7	-	-
1	25	11.2	11.2	0.7	9	65	8316H334 ③⑧	8	-	-
3/2 VALVES, UNIVERSAL (Normally Closed or Normally Open) "Quick Exhaust" with NBR Diaphragm and NBR Disc										
1/4	②	.07	.63	0.3	9	65	8317H307 ①	9	8317H308 ①⑥	10
4/2 VALVES, Brass Body with NBR Disc										
Pipe Size (in)	Orifice Size (mm)	Kv Flow Factor (m ³ /h)		Operating Pressure Differential (bar)		Max. Fluid and Ambient Temp. °C	Single Solenoid		Dual Solenoid	
				Air-Inert Gas			Catalog Number	Const. Ref.	Catalog Number	Const. Ref.
		Pressure to Cylinder	Cylinder to Exhaust	Min.	Max.					
1/4	6	.69	.86	0.7	9	65	8344H370 ①③	11	8344H344 ③†	12
3/8	10	1.3	1.9	0.7	9	65	8344H372 ①③	13	8344H380 ③†	14
1/2	10	1.3	1.9	0.7	9	65	8344H374 ①③	13	8344H382 ③†	14
3/4	19	4.5	4.8	0.7	9	65	8344H376 ①③	15	8344H354 ③†	16
1	19	4.5	4.8	0.7	9	65	8344H378 ①③	15	8344H356 ③†	16

① There are two exhaust flows in the exhaust mode (pilot and main). The pilot exhaust must be connected to the main exhaust when the air or inert gas cannot be exhausted to atmosphere.
 ② For "Quick Exhaust" valves, pressure port is 1/16", exhaust port is 1/4".
 ③ **IMPORTANT:** A Minimum Operating Pressure Differential must be maintained between the pressure and exhaust ports. Supply and exhaust piping must be full area, unrestricted. ASCO flow controls and other similar components must be installed in the cylinder lines only.
 ④ Zero minimum when valve selection gasket is in external position and proper auxiliary air pressure is applied. Minimum 1.0 bar Operating Pressure Differential when selection gasket is in the internal position.
 ⑤ Can be used for **dry** natural gas service with the EF or EV prefix.
 ⑦ Normally closed = 9 bar / Normally open = 7 bar.
 ⑧ Solenoid only approvals with EF or EV prefix, no approvals with general purpose coil (no prefix).
 ⑩ Safety manual and FMEDA (Failure Modes Effects and Diagnostic Analysis) report available.
 ⑪ SIL 3 Capable, Certified by Exida, only valid when used as Normally Closed.
 † Dual solenoid 8344 requires minimum pressure of 20 psi. Single solenoid version has 10 psi minimum pressure requirement.
 †† UL/CSA approved for use with dry natural gas or propane gas with EF or EV prefix without manual operator.

SPECIAL SERVICE PILOT



2/2•3/2•4/2
5/2•5/3
SERIES
Low
Power

Specifications (Metric units)

Body Material	Pipe Size (in)	Orifice Size (mm)	Kv Flow Factor (m ² /h)	Single Solenoid – SIL 3 Capable, Certified by Exida ⑨				Dual Solenoid					
				Operating Pressure Differential (bar)		Max. Fluid Temp. °C	Catalog Number	Const. Ref.	Operating Pressure Differential (bar)		Max. Fluid Temp. °C	Catalog Number	Const. Ref.
				Air-Inert Gas					Air-Inert Gas				
				Min.	Max.	Min.	Max.	Min.	Max.				
3/2, 5/2, 5/3 VALVES, with NBR and PUR Seals													
Aluminum 3/2	1/4	6	.74	2.4	9	65	8551H305 ⑥	17	2	9	65	8551H306 ⑥	17
Aluminum 5/2							8551H317 ⑥	18				8551H318 ⑥	18
Aluminum 5/3 Center Closed							-	18				8551H367 ⑥	18
Aluminum 5/3 Center Open							-	18				8551H368 ⑥	18
Brass 3/2							EF8551H307 ②⑧	17				EF8551H308 ②⑧	17
Brass 5/2							EF8551H319 ②⑧	18				EF8551H320 ②⑧	18
316L Stainless Steel 3/2							EV8551H313 ③⑥⑧	17				EV8551H314 ③⑥⑧	17
316L Stainless Steel 5/2							EV8551H321 ③⑥⑧	18				EV8551H322 ③⑥⑧	18
Aluminum 3/2	1/2	13	3.2	2.4	9	65	8553H305 ⑥	17	2	9	65	8553H306 ⑥	17
Aluminum 5/2							8553H317 ⑥	18				8553H318 ⑥	18
316L Stainless Steel 3/2							EV8553H313 ③⑥⑧	17				EV8553H314 ③⑥⑧	17
316L Stainless Steel 5/2							EV8553H321 ③⑥⑧	18				EV8553H322 ③⑥⑧	18

② Brass construction supplied standard with EF solenoid.
 ③ Stainless steel construction supplied standard with EV solenoid.
 ⑥ Can be used for **dry** natural gas service (no agency approvals) with the EF or EV prefix without manual operator.
 ⑧ Solenoid only approvals with EF or EV prefix, no approvals with general purpose coil (no prefix).
 ⑨ Safety manual and FMEDA (Failure Modes Effects and Diagnostic Analysis) report available.

SPECIAL SERVICE PILOT

Body Material	Pipe Size (in)	Orifice Size (mm)	Kv Flow Factor (m ² /h)	Single Solenoid – SIL 3 Capable, Certified by Exida ⑨				Dual Solenoid					
				Operating Pressure Differential (bar)		Max. Fluid Temp. °C	Catalog Number	Const. Ref.	Operating Pressure Differential (bar)		Max. Fluid Temp. °C	Catalog Number	Const. Ref.
				Air-Inert Gas					Air-Inert Gas				
				Min.	Max.	Min.	Max.						
3/2, 5/2, 5/3 VALVES, with NBR and PUR Seals, NAMUR Mount													
Aluminum 3/2, 5/2	1/4 ①	6	.74	2.4	9	65	8551H301 ①	19	2	9	65	8551H302 ①	19
Aluminum 5/3 Center Closed							-	-				8551H365 ⑥	20
Aluminum 5/3 Center Open							-	-				8551H366 ⑥	20
Brass 3/2, 5/2							EF8551H303 ①②⑧	19				EF8551H304 ①②⑧	19
316L Stainless Steel 3/2, 5/2	1/2	13	3.2	2.4	9	65	EV8551H309 ③⑥	20	2	9	65	EV8551H310 ③⑥	20
Aluminum 3/2, 5/2							8553H301 ⑧	20				8553H302 ⑧	20
316L Stainless Steel 3/2, 5/2							EV8553H309 ③⑥⑧	20				EV8553H310 ③⑥⑧	20

① 1/8" NPT exhaust for 1/4" aluminum and brass.
 ② Brass construction supplied standard with EF solenoid.
 ③ Stainless steel construction supplied standard with EV solenoid.
 ⑥ Can be used for **dry** natural gas service (no agency approvals) with the EF or EV prefix without manual operator.
 ⑧ Solenoid only approvals with EF or EV prefix, no approvals with general purpose coil (no prefix).
 ⑨ Safety manual and FMEDA (Failure Modes Effects and Diagnostic Analysis) report available.

Dimensions: inches (mm)

Const. Ref. 1

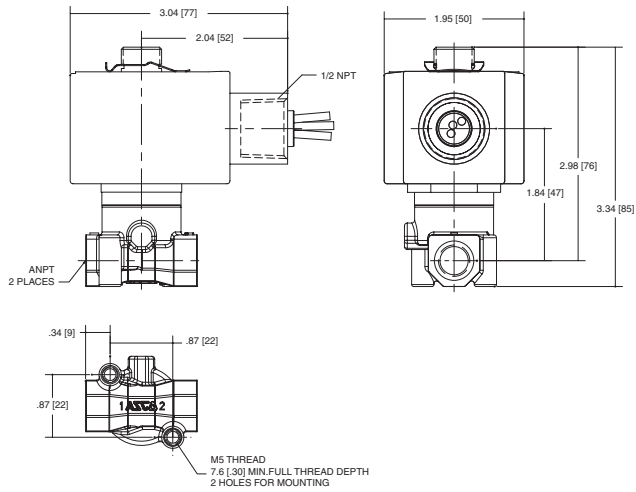

Const. Ref. 2

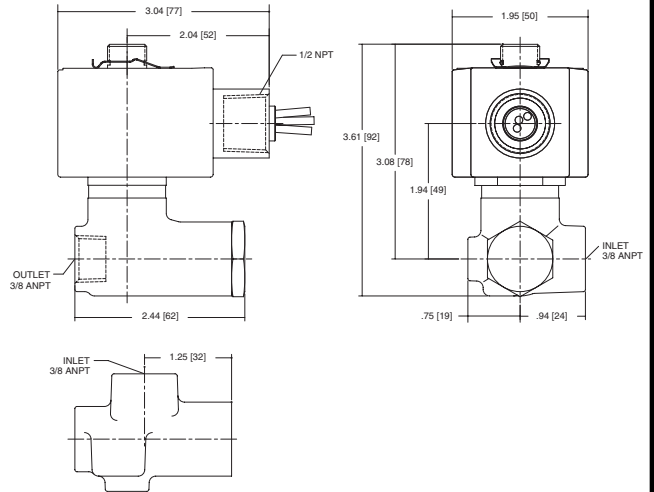

Const. Ref. 3

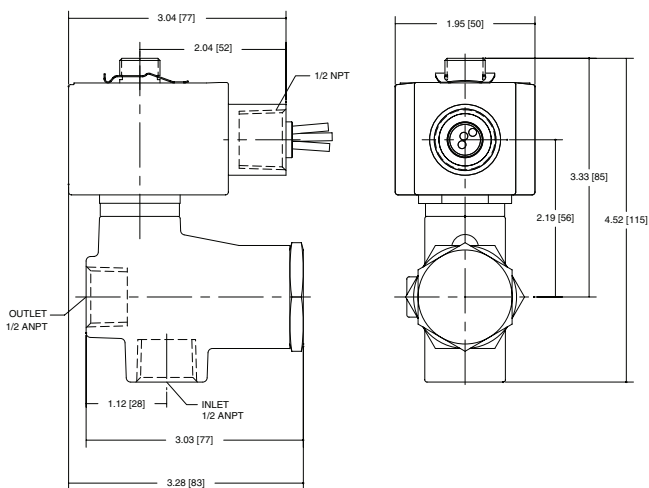

Const. Ref. 4, 5

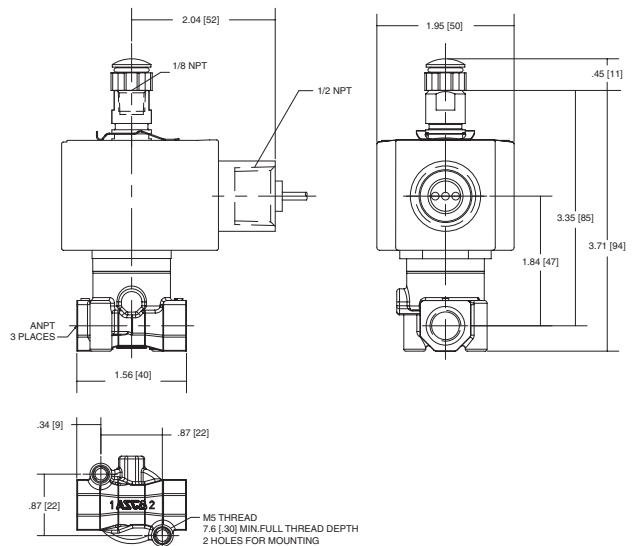

SPECIAL SERVICE
PILOT

Dimensions: inches (mm)

Catalog Number		A	B	C	F	H	K	L	M	N	P	R	S	W
8316H301, 302	in	.84	4.68	2.08	5.41	5.01	2.73	2.06	1.06	1.28	4.23	4.06	3.83	3.26
	mm	21	119	53	137	127	69	52	27	33	107	103	97	83
8316H303, 304	in	1.19	4.88	2.18	5.90	5.40	2.98	2.72	1.24	1.32	4.48	4.26	4.03	3.59
	mm	30	124	56	150	167	76	69	31	34	114	108	102	91
8316H381, 382	in	1.00	4.71	2.11	5.57	5.17	2.73	2.06	1.08	1.28	4.24	4.09	3.86	3.28
	mm	25	120	54	141	131	69	52	27	33	108	104	98	83
8316H384	in	1.11	4.88	2.18	5.98	5.48	2.84	2.72	1.24	1.37	4.34	4.26	4.04	3.59
	mm	28	124	55	152	139	72	69	31	35	110	108	102	91

Const. Ref.		A	B	C	H	K	L	M	N	P	R	W
7	in	1.61	1.41	1.66	6.78	3.68	3.38	2.16	.53	5.09	.50	3.31
	mm	41	36	42	172	93	86	55	13	129	13	84
8	in	-	1.78	-	7.40	3.93	4.44	2.81	.87	5.34	1.74	5.31
	mm	-	45	-	188	100	113	71	22	136	44	135

Const. Ref. 7, 8

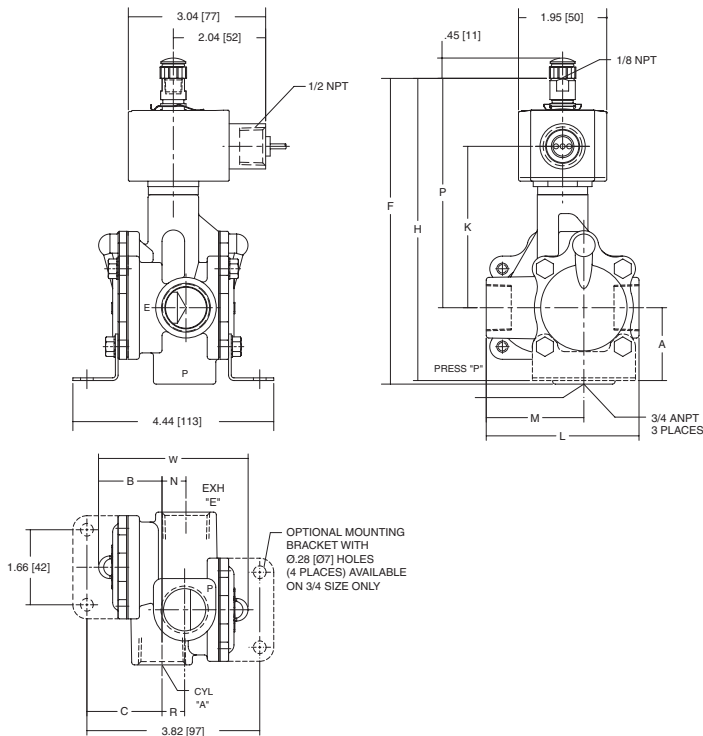

Const. Ref. 6

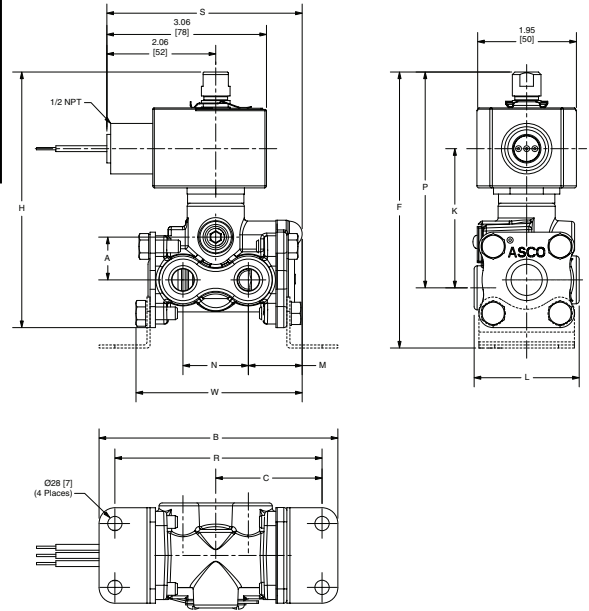

Const. Ref. 9, 10

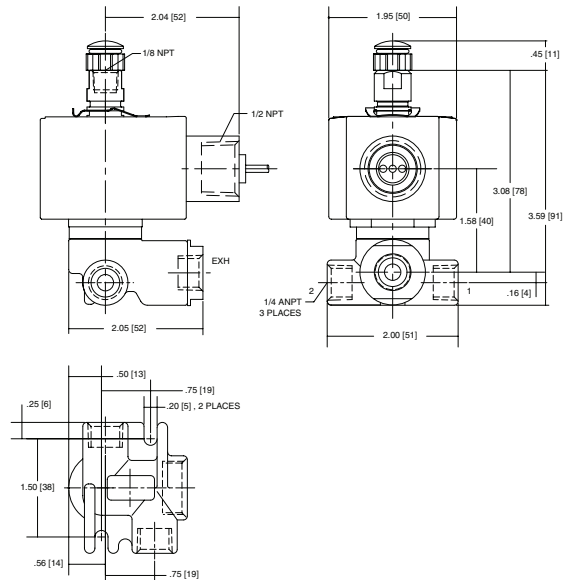

Dimensions: inches (mm)

Catalog Number		A	B	C	D	E	F	G	H	J	K	L	M	N	P	Q
8344H370	in	1.88	1.03	2.15	0.72	2.41	3.21	3.13	1.41	1.36	0.72	4.71	4.65	3.70	2.19	2.22
	mm	48	26	55	18	61	82	80	36	35	18	120	118	94	56	57
8344H372, 374	in	2.62	1.50	2.66	1.06	3.12	3.88	3.18	1.86	1.75	0.83	6.06	4.63	3.51	2.01	2.81
	mm	67	38	68	27	79	99	81	47	45	21	154	118	89	51	71
8344H376, 378	in	3.89	2.10	3.53	1.48	3.79	4.69	4.56	2.12	2.49	1.52	8.22	5.41	3.86	2.36	3.38
	mm	99	53	90	38	96	119	116	54	63	39	209	137	98	60	86

Const. Ref. 11, 13, 15

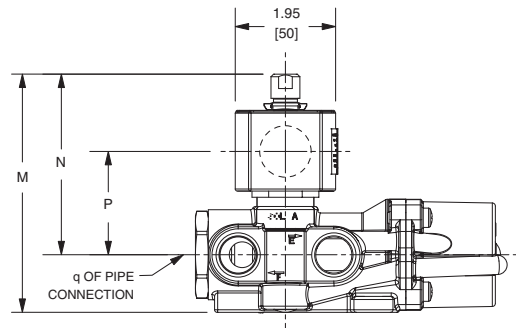
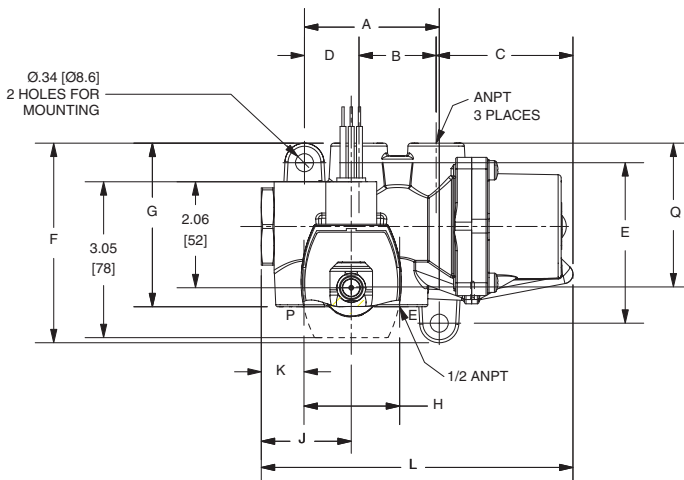

Catalog Number		A	B	C	D	E	F	G	H	J	K	L	M	N	P	Q	R
8344H344	ins.	1.88	2.16	1.03	0.75	2.41	1.69	4.91	2.61	1.41	0.72	1.36	3.92	3.13	2.60	4.70	2.02
	mm	48	55	26	19	61	43	125	66	36	18	35	100	80	51	119	51
8344H354, 356	ins.	3.88	3.53	2.09	1.47	3.81	2.12	8.25	4.34	2.12	1.55	2.51	4.60	4.56	3.07	5.71	2.38
	mm	99	90	53	37	97	54	210	110	54	39	64	125	116	80	145	60
8344H380, 382	ins.	2.62	2.66	1.50	1.06	3.12	1.56	6.06	3.09	1.86	0.83	1.75	4.31	3.18	2.74	4.89	2.11
	mm	67	68	38	27	79	40	154	78	47	21	45	109	81	70	124	54



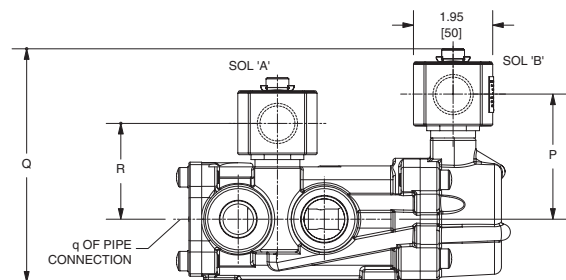
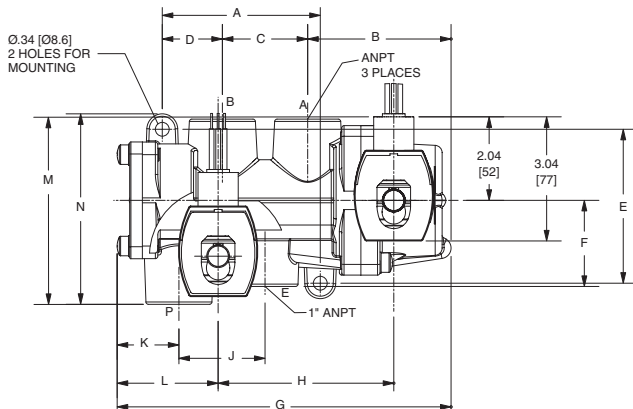

Const. Ref. 12, 14, 16



Dimensions: inches (mm)





Series	8551	8553
NPT	1/4	1/2
L1 ①	5.12 (132)	6.00 (153)
L2 ①	6.73 (171)	7.80 (198)
H2	4.38 (111)	4.77 (121)
H1	1.10 (28)	1.58 (40)
W	1.77 (45)	2.85 (72)

① Manual override option MH adds .250" (6.4),
MS option adds .468" (11.9) to each solenoid endcap.

Optional Manual Operators		
Add Suffix		Description
MO		Push and turn to lock with flat head screwdriver slot
MI		Momentary push in with flat head screwdriver slot
MH		Momentary push in by hand
MS		Push and turn to lock by hand

Series	8551	8553
NPT	1/4	1/2
L1 ①	5.63 (144)	7.06 (180)
L2 ①	7.20 (183)	8.86 (225)
H2	4.38 (111)	4.77 (121)
H1	1.10 (28)	1.58 (40)
W	1.77 (45)	2.85 (72)

① Manual override option MH adds .250" (6.4),
MS option adds .468" (11.9) to each solenoid endcap.

Optional Manual Operators		
Add Suffix		Description
MO		Push and turn to lock with flat head screwdriver slot
MI		Momentary push in with flat head screwdriver slot
MH		Momentary push in by hand
MS		Push and turn to lock by hand

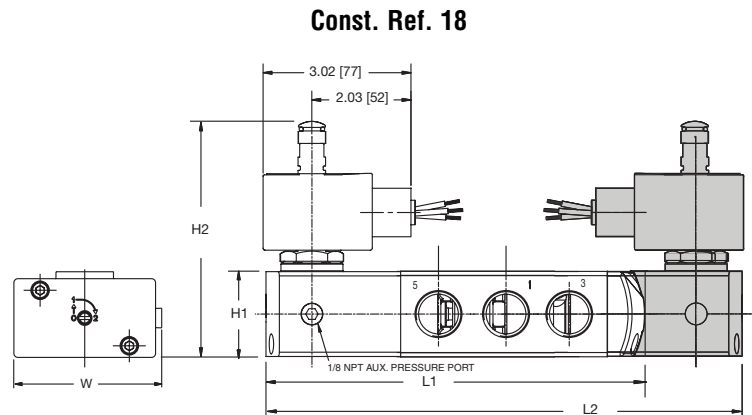
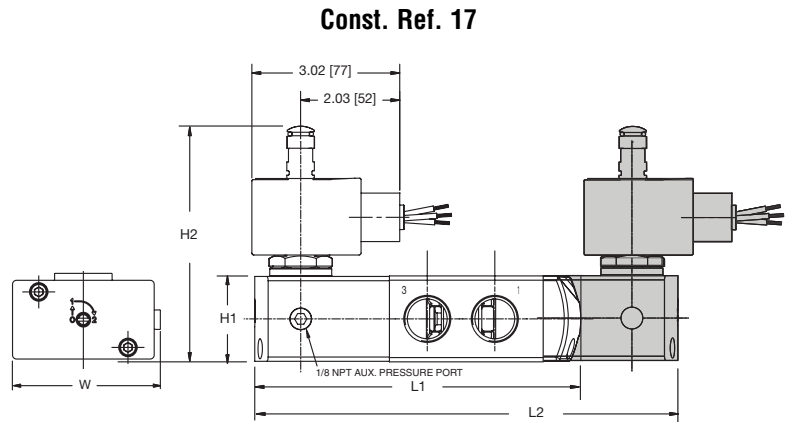

Dimensions: inches (mm)

Series	8551 (Aluminum, Brass)
NPT	1/4
L1 ①	4.96 (126)
L2 ①	6.49 (165)
H2	4.38 (111)
H1	1.57 (40)
W	1.77 (45)

① Manual override option MH adds .250" (6.4), MS option adds .468" (11.9) to each solenoid endcap.

Optional Manual Operators	
Add Suffix	Description
MO	 Push and turn to lock with flat head screwdriver slot
MI	 Momentary push in with flat head screwdriver slot
MH	 Momentary push in by hand
MS	 Push and turn to lock by hand

Series	8551 (316L SS)	8551 (5/3)	8553
NPT	1/4	1/4	1/2
L1 ①	5.20 (132)	-	7.08 (180)
L2 ①	6.73 (171)	7.44 (189)	8.85 (225)
H2	4.38 (111)	4.38 (111)	4.77 (121)
H1	1.57 (40)	1.57 (40)	2.08 (53)
W	1.77 (45)	1.77 (45)	2.87 (73)

① Manual override option MH adds .250" (6.4), MS option adds .468" (11.9) to each solenoid endcap.

Optional Manual Operators	
Add Suffix	Description
MO	 Push and turn to lock with flat head screwdriver slot
MI	 Momentary push in with flat head screwdriver slot
MH	 Momentary push in by hand
MS	 Push and turn to lock by hand

Const. Ref. 19

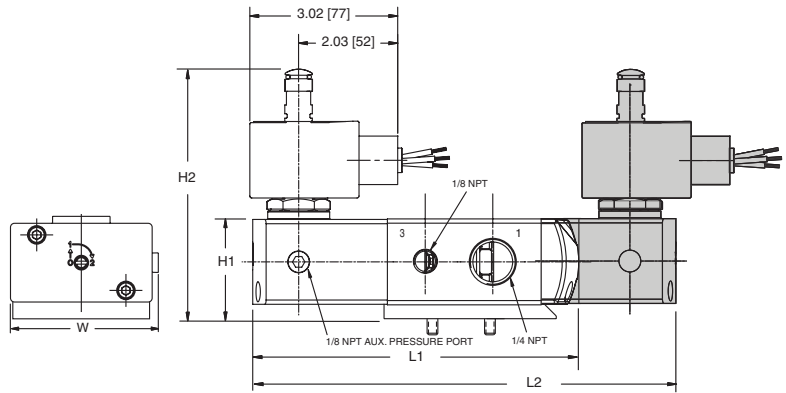

8551 NAMUR Footprint

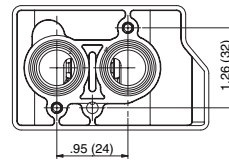

Const. Ref. 20

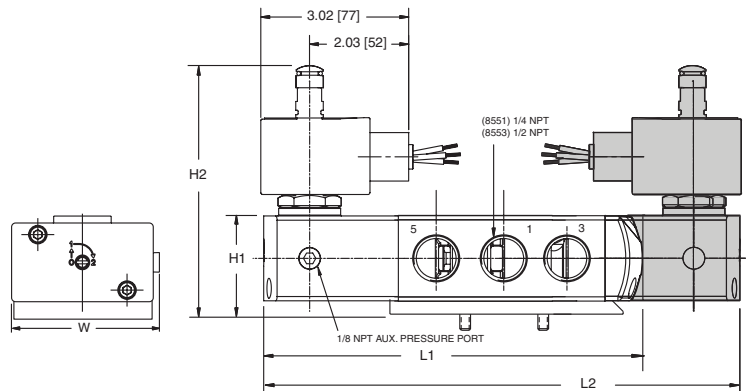

8553 NAMUR Footprint

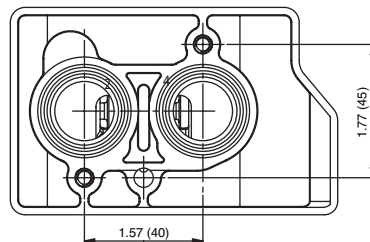

8551 NAMUR Footprint

