

Features

- Molded one-piece solenoid with highly efficient solenoid cartridge and special low wattage coil
- Increased ambient temperature capabilities up to 175°F (80°C)
- Designed for use in automation of plant control systems to provide:
 - PLC compatibility
 - Reduced battery drain
 - Reduced heat rise
 - Reduced wiring cost
- Wide selection includes 2/2 normally closed, 3/2 normally closed (including Quick Exhaust), 3/2 universal, 4/2, 5/2, & 5/3
- Air or inert gas only
- Lower-cost alternative to intrinsically safe valves in critical applications not requiring a safety barrier

Construction

Valve Parts in Contact with Fluids			
Body	Aluminum	Brass	Stainless Steel
Seals and Discs	PUR, NBR, CR, as listed		
Sleeve	304L Stainless Steel		
Core and Plugnut	430F Stainless Steel		
Core Springs	302 Stainless Steel		
Pilot Seat Cartridge (Series 8316 & 8344 only)	POM		
Rider Rings	PTFE		
Spring Retainer	POM		

Electrical

Description	Wattage	Max. Ambient Temp.	T Code	Insulation Class	TPL
Standard Ambient Version	1.4 W	140°F (60°C)	T6	F	-
High Ambient Version	1.8 W	179°F (80°C)	T5	F	#23033
Surge Suppression Version	1.7 W	140°F (60°C)	T5	F	-
Surge Suppression High Ambient Version	2.0 W	179°F (80°C)	T5	F	#23033

ⓘ **IMPORTANT:** Supervisory and leakage current above the drop out current listed will cause improper operation. Consult your local ASCO sales office for additional assistance.

Description	Wattage	Voltage (DC)	Min. Pull In (mA)	3-Way Drop Out (mA) ⓘ	2-Way Drop Out (mA) ⓘ	Coil resistance @ 68°F (20°C) (ohms)
Standard Ambient Version	1.4 W	12V	83.5	13.9	3.2	102
		24V	42.0	7.0	1.6	410
		48V	21.4	3.6	0.8	1640
		120V	8.7	1.4	0.3	10000
High Ambient Version	1.8 W	12V	94.3	15.7	3.6	80
		24V	47.9	8.0	1.8	320
		48V	24.0	4.0	0.9	1260
Surge Suppression Version	1.7 W	12V	94.3	15.7	3.6	80
		24V	47.9	8.0	1.8	320
		48V	22.7	3.8	0.9	1470
Surge Suppression High Ambient Version	2.0 W	12V	105.3	17.6	4.0	64
		24V	54.1	9.0	2.1	270
		48V	24.0	4.0	0.9	1260

24VDC Spare Coil P/N	Standard Ambient Temp. Version	High Ambient Temp Version
General Purpose	238710-902-D*	238710-908-D*
Explosion Proof	238714-902-D*	238714-905-D*
Explosion Proof, Corrosion Resistant	274714-902-D*	274714-905-D*
Explosion Proof, Surge Suppression	276006-006-D*	276006-106-D*
Explosion Proof, Corrosion Resistant, Surge Suppression	276007-006-D*	276007-106-D*

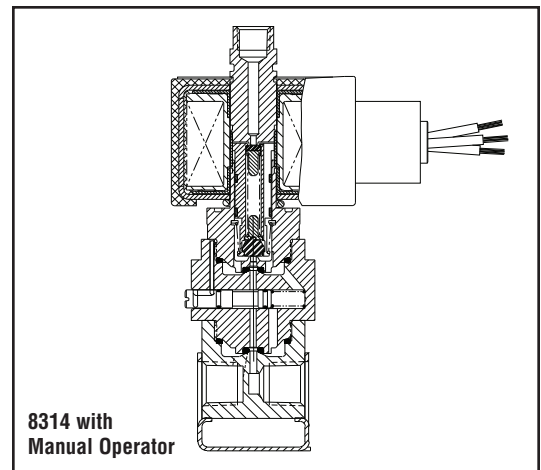
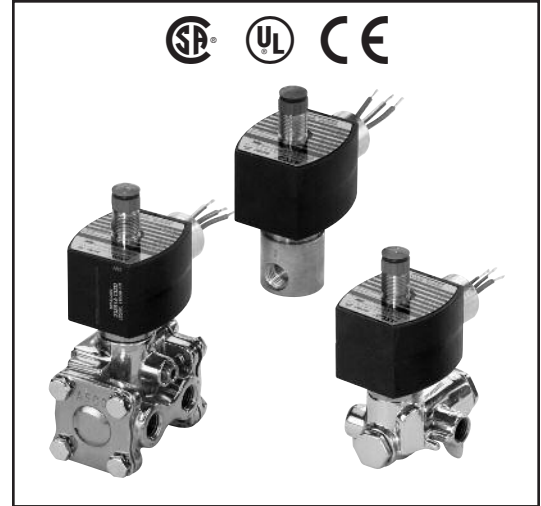

SPECIAL SERVICE PILOT

Ordering

Normal Ambient Version

EV8551G322 24VDC

High Ambient Version (always add TPL #23033)

EFX8316G301-23033 24VDC

Solenoid Enclosures

Standard: Watertight, Types 1, 2, 3, 3S, 4, and 4X.

Optional: Explosionproof and Watertight, Types 3, 3S, 4, 4X, 6, 6P, 7, and 9.

(To order, add prefix "EF" to catalog number. For explosionproof with 316 Stainless Steel hub and trim, specify prefix "EV".) Surge suppression coils also available "MF" prefix.

See *Optional Features Section* for other available options.

Approvals

UL listed General Purpose Valves (Hazardous Location Classified). EV8345G381 solenoid only UL listed. CSA certified; nonincendive for Class I, Division 2 UL E25549. Meets applicable CE directives.

SIL 3 capable per IEC 61508 on 8314 and 8316 const. Third party certification provided by EXIDA.

Refer to *Engineering Section* for details.

Nominal Ambient Temp. Ranges

Series	Body Material	Normal Temperature Range	High Ambient Temp Version
8553	Stainless Steel	-40°F to 140°F (-40°C to 60°C)	Not Available
8551	Brass	-40°F to 140°F (-40°C to 60°C)	
8553	Aluminum	-13°F to 140°F (-25°C to 60°C)	
8551	Aluminum	5°F to 140°F (-15°C to 60°C)	Low Limit is the same as Normal Temperature Ratings, but High Limit is 176°F (80°C)
8551	Stainless Steel	-40°F to 140°F (-40°C to 60°C)	
8262	Brass / Stainless Steel	-40°F to 140°F (-40°C to 60°C)	
8314		-40°F to 140°F (-40°C to 60°C)	
8317		-20°F to 140°F (-29°C to 60°C)	
8316*		-20°F to 140°F (-29°C to 60°C)	
8223	Brass only	-4°F to 140°F (-20°C to 60°C)	
8344		-4°F to 140°F (-20°C to 60°C)	
8316G334		-4°F to 140°F (-20°C to 60°C)	

*Does not include 8316G334; Includes 8316H374. **Note:** 8553 not available in brass

Important

These solenoid valves are intended for use on clean dry air or inert gas, filtered to 40 micrometres or better. The dew point of the media should be at least 10°C (18° F) below the minimum temperature to which any portion of the clean air/inert gas system could be exposed to prevent freezing. If lubricated air is used, the lubricants must be compatible with Nitrile elastomers. Diester oils may cause operational problems. Instrument air in compliance with ANSI/ISA Standard 7.0.01-1996 exceeds the above requirements and is, therefore, an acceptable media for these valves.

Specifications (English units)

Pipe Size (in)	Orifice Size (in)	Cv Flow Factor		Operating Pressure Differential (psi)		Max. Fluid and Ambient Temp. °F	Brass Body		Stainless Steel Body	
				Air-Inert Gas			Catalog Number	Const. Ref.	Catalog Number	Const. Ref.
		Pressure to Cylinder	Cylinder to Exhaust	Min.	Max.					
2/2 VALVES, NORMALLY CLOSED, with NBR Disc										
1/4	1/16	.08		0	150	140	8262G320	18	8262G386 ⑥	18
3/8	5/16	1.5		10	150	140	8223G323	19	-	-
1/2	3/8	3.2		25	150	140	8223G303	20	8223G310 ⑥	20
3/2 VALVES, UNIVERSAL OPERATION (Normally Closed or Normally Open) with NBR Disc – SIL 3 Capable, Certified by Exida ⑦ ⑧										
1/4	1/16	.08	.08	0	150	140	8314G300	1	8314G301 ⑥	2
3/2 VALVES, NORMALLY CLOSED (Closed when de-energized) with NBR Disc – SIL 3 Capable, Certified by Exida ⑦										
1/4	5/16	1.5	1.5	⑤	150	140	8316G301 ③	3	EV8316G381 ⑥	3
3/8	5/16	1.8	1.8	⑤	150	140	8316G302 ③	3	EV8316G382 ⑥	3
3/8	5/8	4	4	⑤	150	140	8316G303 ③	3A	-	-
1/2	5/8	4	4	⑤	150	140	8316G304 ③	3A	EV8316G384 ⑥	3A
3/4	11/16	5.5	5.5	10	150	140	8316H374 ③	4	-	-
1	1	13	13	10	150	140	8316G334 ③	5	-	-
3/2 VALVES, UNIVERSAL (Normally Closed or Normally Open) "Quick Exhaust" with CR Diaphragm and NBR Disc										
1/4	②	.08	.73	5	150	140	8317G307 ①	6	8317G308 ①⑥	7
4/2 VALVES, with NBR Disc and Seals										
1/4	1/16	.08	.08	10	150	140	8345G301 ①③	6	EV8345G381 ①③⑥	8
4/2 VALVES, Brass Body with NBR Disc										
Pipe Size (in)	Orifice Size (in)	Cv Flow Factor		Operating Pressure Differential (psi)		Max. Fluid and Ambient Temp. °F	Single Solenoid		Dual Solenoid	
				Air-Inert Gas			Catalog Number	Const. Ref.	Catalog Number	Const. Ref.
		Pressure to Cylinder	Cylinder to Exhaust	Min.	Max.					
1/4	1/4	.80	1	10	150	140	8344G370 ①③	9	8344G344 ③	12
3/8	3/8	1.4	2.2	10	150	140	8344G372 ①③	11	8344G380 ③	10
1/2	3/8	1.4	2.2	10	150	140	8344G374 ①③	11	8344G382 ③	10
3/4	3/4	5.2	5.6	10	150	140	8344G376 ①③	13	8344G354 ③	14
1	3/4	5.2	5.6	10	150	140	8344G378 ①③	13	8344G356 ③	14

① There are two exhaust flows in the exhaust mode (pilot and main). The pilot exhaust must be connected to the main exhaust when the air or inert gas cannot be exhausted to atmosphere.

② For "Quick Exhaust" valves, pressure port is 1/16", exhaust port is 1/4".

③ **IMPORTANT:** A Minimum Operating Pressure Differential must be maintained between the pressure and exhaust ports. Supply and exhaust piping must be full area, unrestricted. ASCO flow controls and other similar components must be installed in the cylinder lines only.

⑤ Zero minimum when valve selection gasket is in external position and proper auxiliary air pressure is applied. Minimum 15 psi Operating Pressure Differential when selection gasket is in the internal position.

⑥ Can be used for *dry* natural gas service with the EF or EV prefix.

⑦ Safety manual and FMEDA (Failure Modes Effects and Diagnostic Analysis) report available.

⑧ SIL 3 Capable, Certified by Exida, only valid when used as Normally Closed.

Specifications (English units)

Body Material	Pipe Size (in)	Orifice Size (in)	Cv Flow Factor	Single Solenoid					Dual Solenoid				
				Operating Pressure Differential (psi)		Max. Fluid Temp. °F	Catalog Number	Const. Ref.	Operating Pressure Differential (psi)		Max. Fluid Temp. °F	Catalog Number	Const. Ref.
				Air-Inert Gas					Air-Inert Gas				
				Min.	Max.	Min.	Max.						
3/2, 5/2, 5/3 VALVES, with NBR and PUR Seals													
Aluminum 3/2	1/4	1/4	.86	30	150	140	8551G305 ⑦	21	30	150	140	8551G306 ⑦	21
Aluminum 5/2							8551G317 ⑦	22				8551G318 ⑦	22
Aluminum 5/3 Center Closed							-	22				8551G367 ⑦	22
Aluminum 5/3 Center Open							-	22				8551G368 ⑦	22
Brass 3/2							EF8551G307 ②⑦	21				EF8551G308 ②⑦	21
Brass 5/2							EF8551G319 ②⑦	22				EF8551G320 ②⑦	22
316L Stainless Steel 3/2							EV8551G313 ③⑥⑦	21				EV8551G314 ③⑥⑦	21
316L Stainless Steel 5/2	EV8551G321 ③⑥	22	EV8551G322 ③⑥	22									
Aluminum 3/2	1/2	1/2	3.7	30	150	140	8553G305 ⑦	21	30	150	140	8553G306 ⑦	21
Aluminum 5/2							8553G317 ⑦	22				8553G318 ⑦	22
316L Stainless Steel 3/2							EV8553G313 ③⑥⑦	21				EV8553G314 ③⑥⑦	21
316L Stainless Steel 5/2							EV8553G321 ③⑥⑦	22				EV8553G322 ③⑥⑦	22

② Brass construction supplied standard with EF solenoid. ③ Stainless steel construction supplied standard with EV solenoid.
⑥ Can be used for **dry** natural gas service with the EF or EV prefix. ⑦ Solenoid only approvals with EF or EV prefix, no approvals with general purpose coil (no prefix).

SPECIAL SERVICE PILOT

Body Material	Pipe Size (in)	Orifice Size (in)	Cv Flow Factor	Single Solenoid					Dual Solenoid				
				Operating Pressure Differential (psi)		Max. Fluid Temp. °F	Catalog Number	Const. Ref.	Operating Pressure Differential (psi)		Max. Fluid Temp. °F	Catalog Number	Const. Ref.
				Air-Inert Gas					Air-Inert Gas				
				Min.	Max.	Min.	Max.						
3/2, 5/2, 5/3 VALVES, with NBR and PUR Seals, NAMUR Mount													
Aluminum 3/2, 5/2	1/4	1/4	.86	30	150	140	8551G301 ①	23	30	150	140	8551G302 ①	23
Aluminum 5/3 Center Closed							-	-				8551G365 ⑦	24
Aluminum 5/3 Center Open							-	-				8551G366 ⑦	24
Brass 3/2, 5/2							EF8551G303 ②①⑦	23				EF8551G304 ②①⑦	23
316L Stainless Steel 3/2, 5/2	1/2	1/2	3.7	30	150	140	EV8551G309 ③⑥	24	30	150	140	EV8551G310 ③⑥	24
Aluminum 3/2, 5/2							8553G301 ⑦	24				8553G302 ⑦	24
316L Stainless Steel 3/2, 5/2							EV8553G309 ③⑥⑦	24				EV8553G310 ③⑥⑦	24

① 1/8" NPT exhaust for 1/4" aluminum and brass. ② Brass construction supplied standard with EF solenoid. ③ Stainless steel construction supplied standard with EV solenoid.
⑥ Can be used for **dry** natural gas service with the EF or EV prefix. ⑦ Solenoid only approvals with EF or EV prefix, no approvals with general purpose coil (no prefix).

Specifications (Metric units)

Pipe Size (in)	Orifice Size (mm)	Kv Flow Factor (m ³ /h)		Operating Pressure Differential (bar)		Max. Fluid and Ambient Temp. °C	Brass Body		Stainless Steel Body	
				Air-Inert Gas			Catalog Number	Const. Ref.	Catalog Number	Const. Ref.
		Pressure to Cylinder	Cylinder to Exhaust	Min.	Max.					
2/2 VALVES, NORMALLY CLOSED, with NBR Disc										
1/4	2	.07		0	10	60	8262G320	18	8262G386 ⑥	18
3/8	8	1.29		0.7	10	60	8223G323	19	-	-
1/2	10	2.74		1.7	10	60	8223G303	20	8223G310 ⑥	20
3/2 VALVES, UNIVERSAL OPERATION (Normally Closed or Normally Open) with NBR Disc – SIL 3 Capable, Certified by Exida ⑦ ⑧										
1/4	2	.07	.07	0	10	60	8314G300	1	8314G301 ⑥	2
3/2 VALVES, NORMALLY CLOSED (Closed when de-energized) with NBR Disc – SIL 3 Capable, Certified by Exida ⑦										
1/4	8	1.29	1.29	⑤	10	60	8316G301 ③	3	EV8316G381 ⑥	3
3/8	8	1.37	1.37	⑤	10	60	8316G302 ③	3	EV8316G382 ⑥	3
3/8	16	2.57	2.57	⑤	10	60	8316G303 ③	3A	-	-
1/2	16	3.43	3.43	⑤	10	60	8316G304 ③	3A	EV8316G384 ⑥	3A
3/4	17	4.71	4.71	0.7	10	60	8316H374 ③	4	-	-
1	25	11.14	11.14	0.7	10	60	8316G334 ③	5	-	-
3/2 VALVES, UNIVERSAL (Normally Closed or Normally Open) "Quick Exhaust" with CR Diaphragm and NBR Disc										
1/4	②	.07	.63	0.3	10	60	8317G307 ①	6	8317G308 ①⑥	7
4/2 VALVES, with NBR Disc and Seals										
1/4	2	.07	.07	0.7	10	60	8345G301 ①③	6	EV8345G381 ①③⑥	8
4/2 VALVES, Brass Body with NBR Disc										
Pipe Size (in)	Orifice Size (mm)	Kv Flow Factor (m ³ /h)		Operating Pressure Differential (bar)		Max. Fluid and Ambient Temp. °C	Single Solenoid		Dual Solenoid	
				Air-Inert Gas			Catalog Number	Const. Ref.	Catalog Number	Const. Ref.
		Pressure to Cylinder	Cylinder to Exhaust	Min.	Max.					
1/4	6	0.69	0.86	0.7	10	60	8344G370 ①③	9	8344G344 ③	12
3/8	10	1.20	1.89	0.7	10	60	8344G372 ①③	11	8344G380 ③	10
1/2	10	1.20	1.89	0.7	10	60	8344G374 ①③	11	8344G382 ③	10
3/4	19	4.46	4.80	0.7	10	60	8344G376 ①③	13	8344G354 ③	14
1	19	4.46	4.80	0.7	10	60	8344G378 ①③	13	8344G356 ③	14

① There are two exhaust flows in the exhaust mode (pilot and main). The pilot exhaust must be connected to the main exhaust when the air or inert gas cannot be exhausted to atmosphere.
 ② For "Quick Exhaust" valves, pressure port is 1/16", exhaust port is 1/4".
 ③ **IMPORTANT:** A Minimum Operating Pressure Differential must be maintained between the pressure and exhaust ports. Supply and exhaust piping must be full area, unrestricted. ASCO flow controls and other similar components must be installed in the cylinder lines only.
 ④ Zero minimum when valve selection gasket is in external position and proper auxiliary air pressure is applied. Minimum 1.0 bar Operating Pressure Differential when selection gasket is in the internal position.
 ⑤ Can be used for *dry* natural gas service with the EF or EV prefix.
 ⑥ Safety manual and FMEDA (Failure Modes Effects and Diagnostic Analysis) report available.
 ⑦ SIL 3 Capable, Certified by Exida, only valid when used as Normally Closed.

SPECIAL SERVICE PILOT

Specifications (Metric units)

Body Material	Pipe Size (in)	Orifice Size (mm)	Kv Flow Factor (m3/h)	Single Solenoid					Dual Solenoid				
				Operating Pressure Differential (bar)		Max. Fluid Temp. °C	Catalog Number	Const. Ref.	Operating Pressure Differential (bar)		Max. Fluid Temp. °C	Catalog Number	Const. Ref.
				Air-Inert Gas					Air-Inert Gas				
				Min.	Max.	Min.	Max.						
3/2, 5/2, 5/3 VALVES, with NBR and PUR Seals													
Aluminum 3/2	1/4	6	.7	2	10	60	8551G305 ⑦	21	2	10	60	8551G306 ⑦	21
Aluminum 5/2							8551G317 ⑦	22				8551G318 ⑦	22
Aluminum 5/3 Center Closed							-	22				8551G367 ⑦	22
Aluminum 5/3 Center Open							-	22				8551G368 ⑦	22
Brass 3/2							EF8551G307 ②⑦	21				EF8551G308 ②⑦	21
Brass 5/2							EF8551G319 ②⑦	22				EF8551G320 ②⑦	22
316L Stainless Steel 3/2							EV8551G313 ③⑥⑦	21				EV8551G314 ③⑥⑦	21
316L Stainless Steel 5/2							EV8551G321 ③⑥	22				EV8551G322 ③⑥	22
Aluminum 3/2	1/2	13	3.15	2	10	60	8553G305 ⑦	21	2	10	60	8553G306 ⑦	21
Aluminum 5/2							8553G317 ⑦	22				8553G318 ⑦	22
316L Stainless Steel 3/2							EV8553G313 ③⑥⑦	21				EV8553G314 ③⑥⑦	21
316L Stainless Steel 5/2							EV8553G321 ③⑥⑦	22				EV8553G322 ③⑥⑦	22

② Brass construction supplied standard with EF solenoid. ③ Stainless steel construction supplied standard with EV solenoid.
 ⑥ Can be used for **dry** natural gas service with the EF or EV prefix. ⑦ Solenoid only approvals with EF of EV prefix, no approvals with general purpose coil (no prefix).

SPECIAL SERVICE
PILOT

Body Material	Pipe Size (in)	Orifice Size (mm)	Kv Flow Factor (m3/h)	Single Solenoid					Dual Solenoid				
				Operating Pressure Differential (bar)		Max. Fluid Temp. °C	Catalog Number	Const. Ref.	Operating Pressure Differential (bar)		Max. Fluid Temp. °C	Catalog Number	Const. Ref.
				Air-Inert Gas					Air-Inert Gas				
				Min.	Max.	Min.	Max.						
3/2, 5/2, 5/3 VALVES, with NBR and PUR Seals, NAMUR Mount													
Aluminum 3/2, 5/2	1/4 ①	6	.7	2	10	60	8551G301 ①	23	2	10	60	8551G302 ①	23
Aluminum 5/3 Center Closed							-	-				8551G365 ⑦	24
Aluminum 5/3 Center Open							-	-				8551G366 ⑦	24
Brass 3/2, 5/2							EF8551G303 ②①⑦	23				EF8551G304 ②①⑦	23
316L Stainless Steel 3/2, 5/2	1/2	13	3.15	2	10	60	EV8551G309 ③⑥	24	2	10	60	EV8551G310 ③⑥	24
Aluminum 3/2, 5/2							8553G301 ⑦	24				8553G302 ⑦	24
316L Stainless Steel 3/2, 5/2							EV8553G309 ③⑥⑦	24				EV8553G310 ③⑥⑦	24

① 1/8" NPT exhaust for 1/4" aluminum and brass. ② Brass construction supplied standard with EF solenoid. ③ Stainless steel construction supplied standard with EV solenoid.
 ⑥ Can be used for **dry** natural gas service with the EF or EV prefix. ⑦ Solenoid only approvals with EF of EV prefix, no approvals with general purpose coil (no prefix).

Dimensions: inches (mm)

Const. Ref. 1, 2

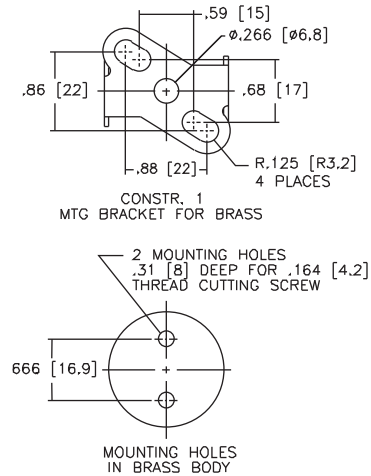
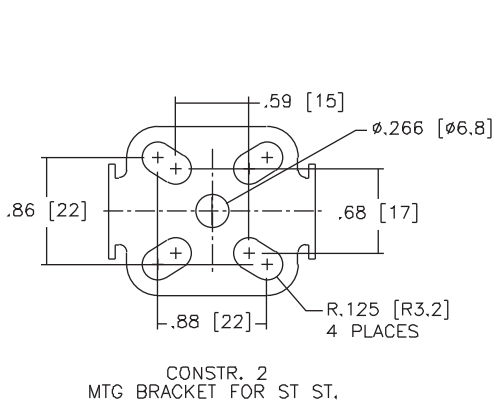
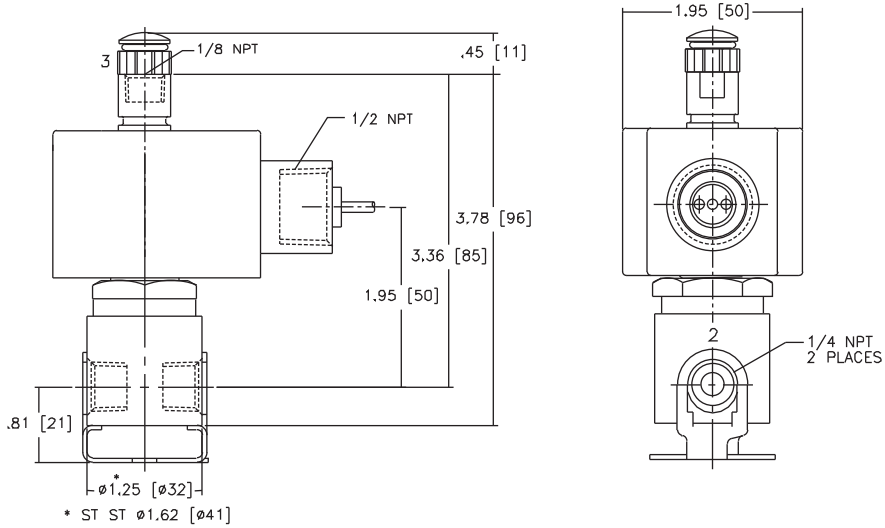

SPECIAL SERVICE
PILOT

Dimensions: inches (mm)

Const. Ref. 3

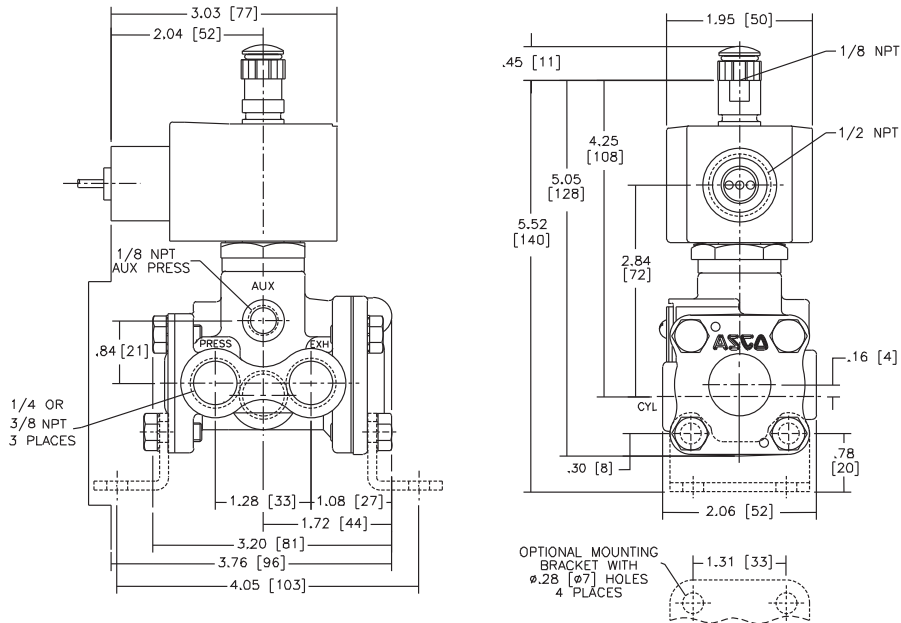

Const. Ref. 3A

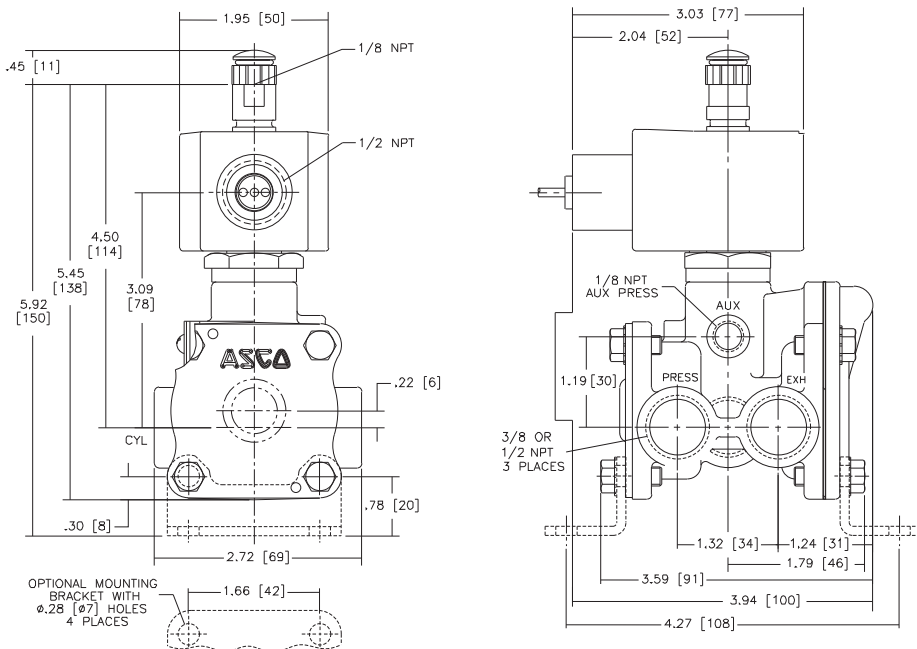

SPECIAL SERVICE
PILOT

Dimensions: inches (mm)

Const. Ref.		A	B	C	H	K	L	M	N	P	R	W
4	in	1.61	1.41	1.66	6.78	3.68	3.38	2.16	.53	5.09	.50	3.31
	mm	41	36	42	172	93	86	55	13	129	13	84
5	in	X	1.78	X	7.40	3.93	4.44	2.81	.87	5.34	1.74	5.31
	mm	X	45	X	188	100	113	71	22	136	44	135

Const. Ref. 4, 5

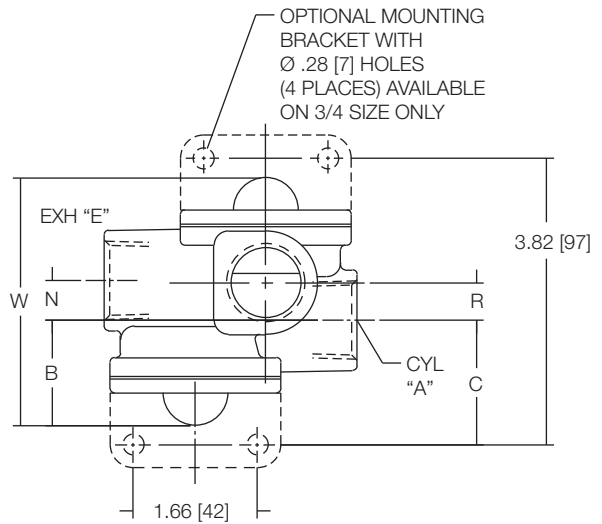
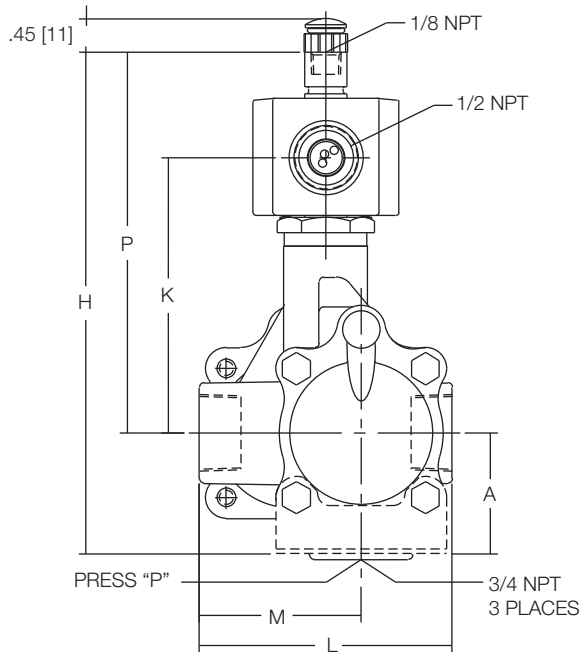

Const. Ref. 6, 7

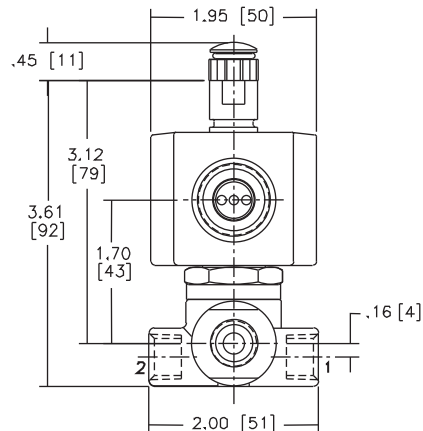
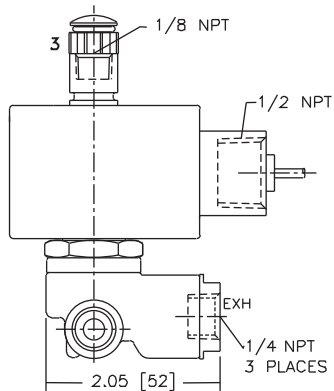

Dimensions: inches (mm)

Const. Ref. 8

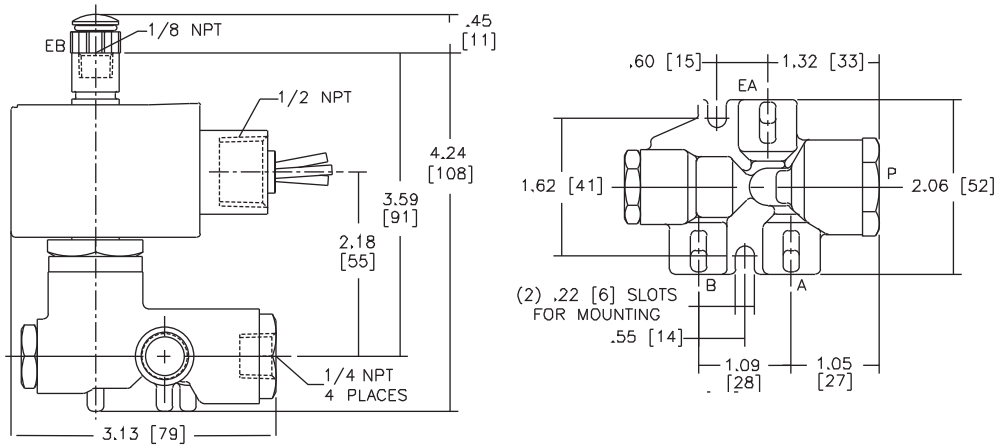

Const. Ref. 18

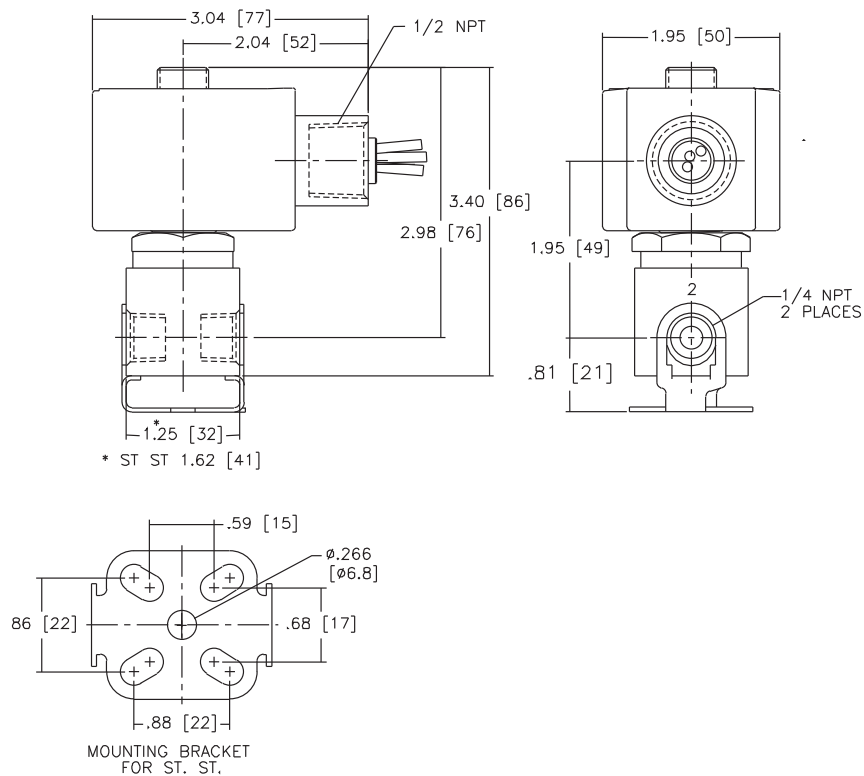

Dimensions: inches (mm)

Const. Ref.		Dia "D"	E	F	G	H	J	K	L	N	P	W	X	Y	Z	Exhaust Pipe Size
9	in	Ø .28	.56	2.41	1.88	4.67	1.03	2.30	3.12	.72	3.72	4.75	1.41	1.56	.81	3/8
	mm	7	14	61	48	119	26	58	79	18	95	121	36	40	21	
10	in	Ø .34	.76	3.12	2.62	4.89	1.50	2.11	3.18	.83	3.77	6.06	1.86	1.89	.83	1/2
	mm	9	16	79	67	118	38	70	81	21	90	154	48	49	21	
11	in	Ø .34	.76	3.12	2.62	4.65	1.50	2.11	3.18	.83	3.53	6.06	1.86	1.89	.83	1/2
	mm	9	35	97	99	138	53	54	116	40	99	210	54	67	30	
12	in	Ø .28	.56	2.41	1.88	5.06	1.03	2.71	3.12	.72	4.12	4.81	1.41	1.56	.81	3/8
	mm	7	14	61	48	129	26	69	79	18	105	122	36	40	21	
13	in	Ø .34	.78	3.12	2.62	5.27	1.50	2.49	3.19	.84	4.16	6.06	1.88	1.91	.84	1
	mm	9	16	79	67	134	38	63	81	21	106	154	48	49	21	
14	in	Ø .34	1.38	3.81	3.88	6.09	2.09	3.18	4.56	1.56	4.59	8.25	2.12	2.62	1.16	1
	mm	9	35	97	99	155	53	81	116	40	117	210	54	67	30	

Const. Ref. 9, 10, 11, 12, 13, 14

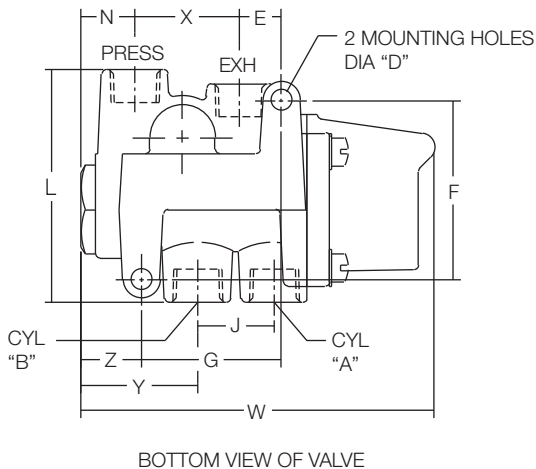
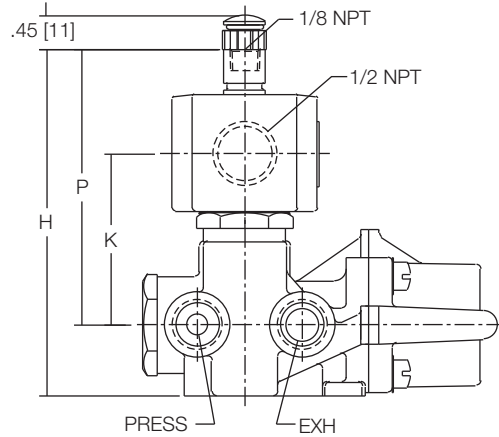
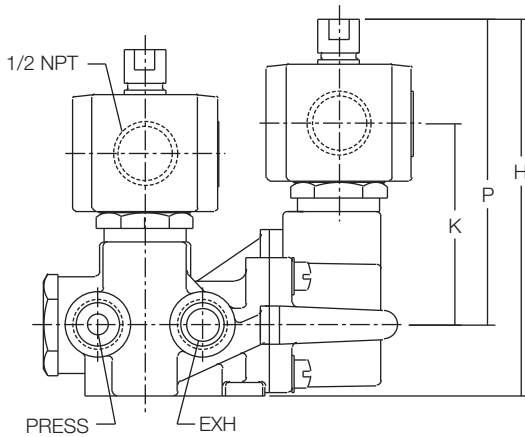

BOTTOM VIEW OF VALVE

SPECIAL SERVICE
PILOT

Dimensions: inches (mm)

Const. Ref. 19

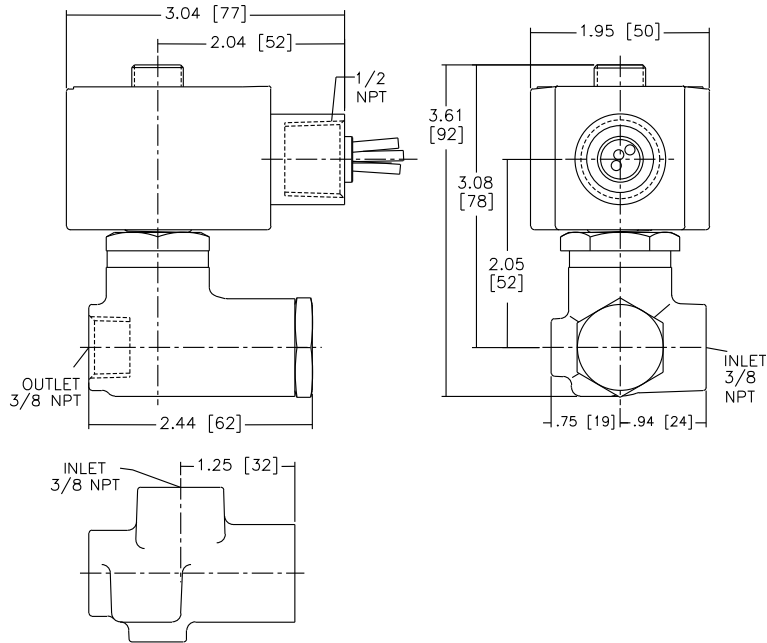



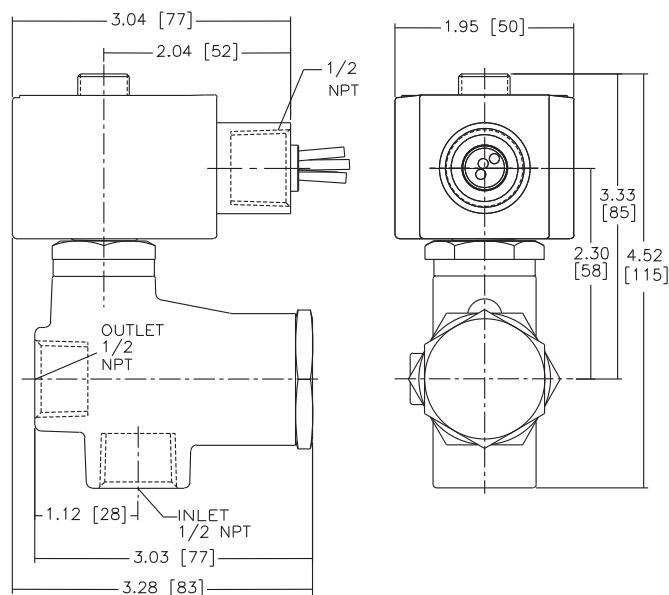

Const. Ref. 20



Dimensions: inches (mm)





Series	8551	8553
NPT	1/4	1/2
L1 ①	5.12 (132)	6.00 (153)
L2 ①	6.73 (171)	7.80 (198)
H2	4.38 (111)	4.77 (121)
H1	1.10 (28)	1.58 (40)
W	1.77 (45)	2.85 (72)

① Manual override option MH adds .250" (6.4),
MS option adds .468" (11.9) to each solenoid endcap.

Optional Manual Operators		
Add Suffix		Description
MO		Push and turn to lock with flat head screwdriver slot
MI		Momentary push in with flat head screwdriver slot
MH		Momentary push in by hand
MS		Push and turn to lock by hand

Series	8551	8553
NPT	1/4	1/2
L1 ①	5.63 (144)	7.06 (180)
L2 ①	7.20 (183)	8.86 (225)
H2	4.38 (111)	4.77 (121)
H1	1.10 (28)	1.58 (40)
W	1.77 (45)	2.85 (72)

① Manual override option MH adds .250" (6.4),
MS option adds .468" (11.9) to each solenoid endcap.

Optional Manual Operators		
Add Suffix		Description
MO		Push and turn to lock with flat head screwdriver slot
MI		Momentary push in with flat head screwdriver slot
MH		Momentary push in by hand
MS		Push and turn to lock by hand

Const. Ref. 21

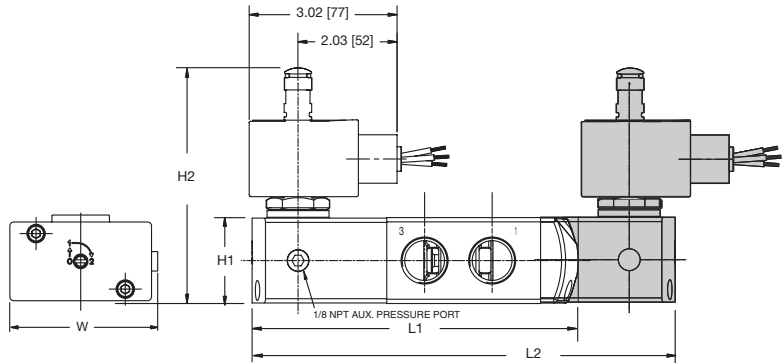

Const. Ref. 22

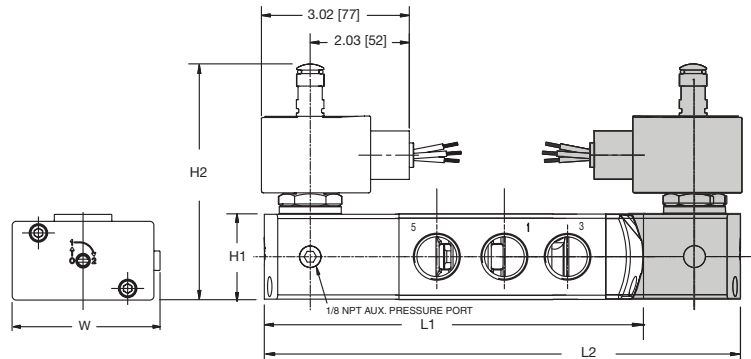

Dimensions: inches (mm)

Series	8551 (Aluminum, Brass)
NPT	1/4
L1 ①	4.96 (126)
L2 ①	6.49 (165)
H2	4.38 (111)
H1	1.57 (40)
W	1.77 (45)

① Manual override option MH adds .250" (6.4),
MS option adds .468" (11.9) to each solenoid endcap.

Optional Manual Operators		
Add Suffix		Description
MO		Push and turn to lock with flat head screwdriver slot
MI		Momentary push in with flat head screwdriver slot
MH		Momentary push in by hand
MS		Push and turn to lock by hand

Series	8551 (316L SS)	8551 (5/3)	8553
NPT	1/4	1/4	1/2
L1 ①	5.20 (132)	-	7.08 (180)
L2 ①	6.73 (171)	7.44 (189)	8.85 (225)
H2	4.38 (111)	4.38 (111)	4.77 (121)
H1	1.57 (40)	1.57 (40)	2.08 (53)
W	1.77 (45)	1.77 (45)	2.87 (73)

① Manual override option MH adds .250" (6.4),
MS option adds .468" (11.9) to each solenoid endcap.

Optional Manual Operators		
Add Suffix		Description
MO		Push and turn to lock with flat head screwdriver slot
MI		Momentary push in with flat head screwdriver slot
MH		Momentary push in by hand
MS		Push and turn to lock by hand

Const. Ref. 23

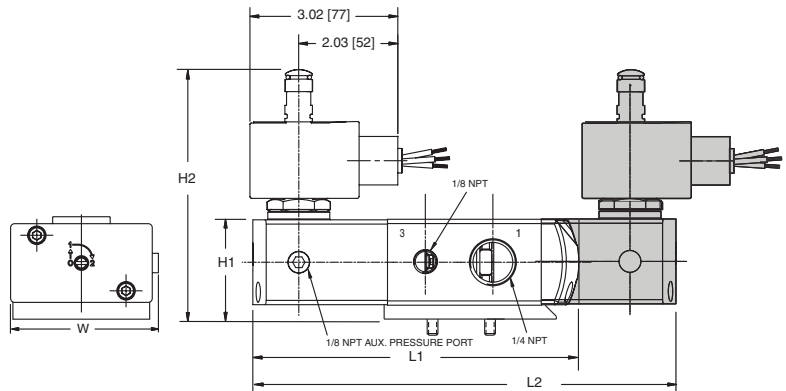

8551 NAMUR Footprint

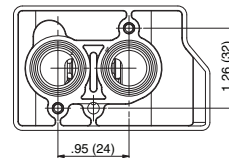

Const. Ref. 24

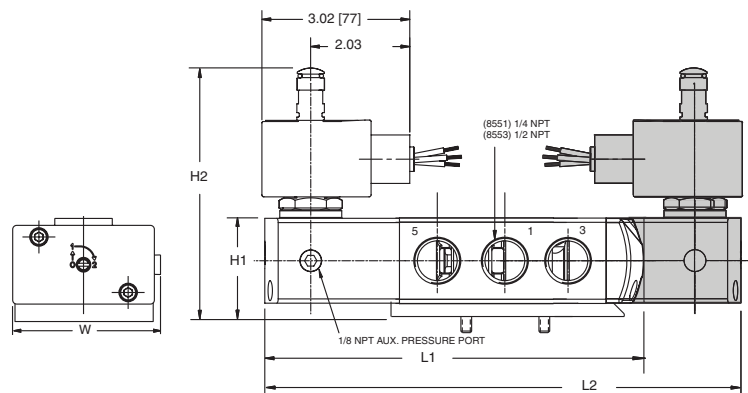

8553 NAMUR Footprint

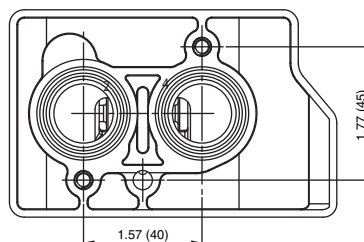

8551 NAMUR Footprint

