

# ASCO<sup>®</sup> RedHat<sup>™</sup>

NEXT GENERATION

- Higher DC pressure rating
- 80% reduction in power consumption
- Built-in surge suppression
- 3-year coil warranty
- Class I, Division 2 coils available

ELECTRONICALLY ENHANCED SOLENOID VALVES

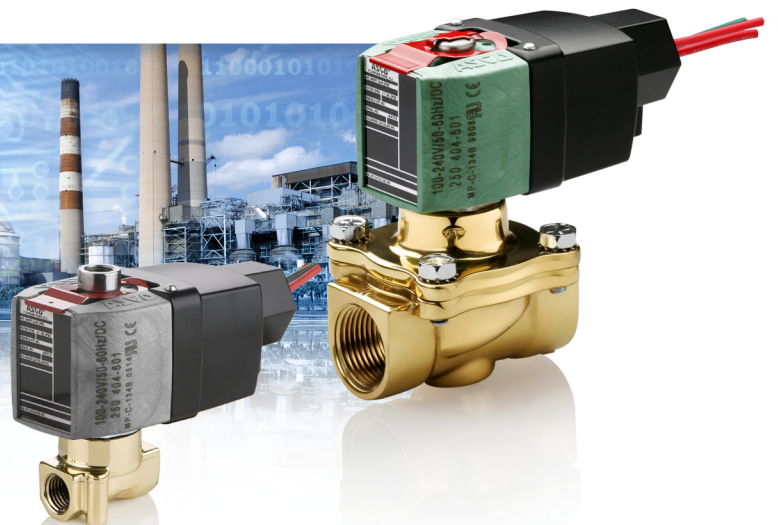

## RedHat Next Generation | Electronically Enhanced Solenoid Valve Technology

**RedHat Next Generation is the future of solenoid valve technology, designed and manufactured to provide new capabilities. The Next Generation of solenoid valves provides lower operating cost, and represents an advancement in the performance, reliability, and ruggedness that you have come to expect from ASCO.**

### Electronics technology to manage power

RedHat Next Generation valves use electronics technology to manage power, providing a new standard of operation. The solenoid incorporates a power management circuit providing lower power consumption, enhanced pressure and flow ratings, and electrical surge suppression to both the solenoid and electronic controls.

### Only 2 watts of power

The new solenoid draws only 2 watts of power. A conventional solenoid with the same performance can draw as high as 17 watts of power. The savings in power usage over the installed life of the valve will lower the total cost of ownership up to 14%.

### Increased DC performance

The new technology accepts both AC and DC voltages without sacrificing flow or pressure specifications. DC performance has been increased by 150% to 500% from today's industry standards, making the valves' DC characteristics equivalent to AC pressure and flow values. This simplifies your control by eliminating the need for AC output cards, reduces wiring costs, and provides safer working environments for users operating on DC.

RedHat Next Generation coils are offered in three voltage ranges covering most electrical requirements – 100-240/AC or DC, 24-120/AC or DC, or 12-24/DC. Each coil has built-in electrical surge suppression that protects the coil from external voltage spikes and eliminates inductive voltage spikes associated with conventional solenoids. An optional solenoid is available for use in Class I, Division 2 hazardous locations.

### Rugged Design

ASCO RedHat Next Generation addresses many other operating characteristics that will further improve the life of your solenoid valves. These include a much lower temperature rise, and an increase in valve ambient temperature rating to 140°F/60°C. Because of our confidence in the rugged design of the RedHat Next Generation solenoids, ASCO is pleased to extend a 3-year warranty on the coils.



Visit us online at [www.ascovalve.com](http://www.ascovalve.com) to see our comprehensive product portfolio.

## ELECTRONICALLY ENHANCED SOLENOID VALVES

- 1/2 inch female conduit
- Polyester coated aluminum conduit hub
- Enclosure Types 1 through 4X
- Now standard with 24 inch leads
- Stainless steel nameplate
- Steel clip with epoxy powder coated paint
- LCP overmolded coil
- Optional Class 1, Division 2 coil available for hazardous locations



## VALVE SELECTION & ORDERING

As you use this catalog to select RedHat Next Generation products, note these key operating features:

- Increase in DC pressure ratings to AC levels on all products (up to a 500% improvement)
- Lower power operation
- Voltage ranging
- Built in surge suppression
- Elimination of AC hum
- Increase in AC and DC operating temperatures
- Low solenoid temperature rise
- Longer coil life due to lower operating temperatures and electrical surge suppression
- Solenoid approvals to UL, CSA, and CE standards

### How to order

Find the valve that you are looking for in the provided specifications tables. The tables contain the following information designed to help you in making your selection:

Pipe Size (in)	Orifice Dia. (in)	Cv Flow	Operating Pressure Differential (psi)				Max Fluid Temp. °F	Brass ①	Const. Ref.	Agency UL	Stainless Steel	Const. Ref.	Agency UL	Wattage AC/DC	Approx. Shipping Weight (lbs.)
			Max. AC/DC												
			Min.	Air-Inert Gas	Water	Light Oil @ 300 SSU									
1/2	5/8	4	0	150	150	-	180	8210P094	4	○	-	-	-	2	3.2

① When ordering a valve product, specify the ASCO base catalog number (Ex. **8210P094**). This number will always be 8 digits long.

Choose one of the three operating voltage ranges (100-240V/50-60Hz/DC, 24-120V/50-60Hz/DC or 12-24/DC) and add it to the base catalog number (Ex. 8210P094 **24-120V/50-60Hz/DC**).

If you want to enhance the product with one or more of the options allowed in the Optional Features Chart for that catalog number, please add the appropriate prefix or suffix (as shown):

Pipe Size (in)	Orifice Dia. (in)	Solenoid Options ②	Base Catalog Number		Resilient Materials ③							Other ③		Standard Rebuild Kit ④		
		Class I, Division 2 Coil	Brass	Stainless Steel	NBR	FKM	EPDM	CR	Oxygen Service	PTFE	Urethane	Vacuum	Manual Operator	Mounting Bracket	Brass AC/DC	Stainless Steel AC/DC
1/2	5/8	EE	8210P094	-	●	V	E	J	N	-	-	VH	MO	MB	322670	-

② Optional Class I, Division 2 solenoid (Ex. **EE8210P094** 24-120V/50-60Hz/DC)

③ If an FKM elastomer and manual operator are required, add VMO to the back of the base catalog number. (Ex. 8210P094**VMO** 24-120V/50-60Hz/DC)

④ When ordering a rebuild kit for a valve, supply the rebuild kit number as shown in the table. (Ex. 322670) When ordering a rebuild kit for a valve with a suffix, add the suffix to the appropriate standard rebuild kit. (Ex. The rebuild kit for the above valve with FKM is 322670-V)

**All constructions are available with prefix EE for Class I, Division 2 requirements.**

### Solenoid Enclosures

**Standard:** Watertight, Types 1, 2, 3, 3S, 4, and 4X.

**Optional:** Class I, Division 2 for Hazardous Locations and Watertight, Types 3, 3S, 4, 4X. (To order, add prefix "EE" to catalog number.)

**When ordering a replacement coil, select from the following:**

Voltage Range	Valve Prefix	Replacement Coil Part Number
100-240V/50-60Hz/DC	-	250404-601-*
24-120V/50-60Hz/DC	-	250404-604-*
12-24/DC	-	250404-603-*
100-240V/50-60Hz/DC	EE	250504-601-*
24-120V/50-60Hz/DC	EE	250504-604-*
12-24/DC	EE	250504-603-*

⚠ **Warning:** Improper selection or use of products and related items in this catalog can cause death, serious injury or property damage. If you need any assistance in selecting, specifying, or ordering a valve, please contact ASCO at (800) 972-2726.

## NEXT GENERATION | CONTENTS

### **2-Way Valves**

2-Way Normally Closed	1-2
2-Way Normally Open	1-2
2-Way Dimensional Drawings	3-4

### **3-Way Valves**

3-Way Normally Closed	5-6
3-Way Normally Open	5-6
3-Way Universal	5-6
3-Way Dimensional Drawings	7-8

### **4-Way Valves**

Dimensional Drawings	10
----------------------	----

<b>Engineering Information</b>	12-18
--------------------------------	-------

- Two-way (2/2) Next Generation solenoid valves have one inlet port and one outlet port.
- Control of air, water, light oil, and non-corrosive media.
- Normally closed (opens when energized) and normally open (closed when energized) operation.
- Pipe sizes – 1/8 to 2 inch.

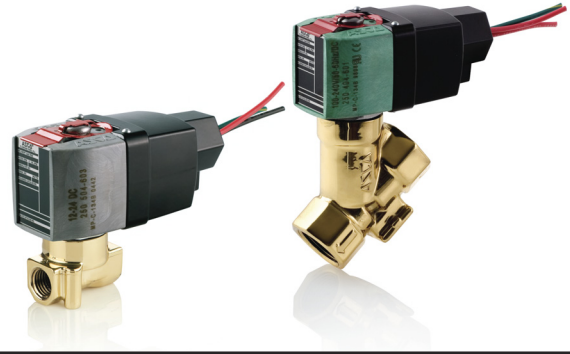

Specifications

Pipe Size (in)	Orifice Dia. (in)	Cv Flow	Operating Pressure Differential (psi)				Max Fluid Temp. °F	Brass	Const. Ref.	Agency		Stainless Steel	Const. Ref.	Agency		Wattage AC/DC
			Min.	Max. AC/DC						UL	UL					
				Air-Inert Gas	Water ®	Light Oil @ 300 SSU										
<b>General Service - Normally Closed</b>																
1/8	3/64	0.06	0	2200	2200	1700	140	-	-	-	8262R175 ⑤	1	●	-	2	
1/8	3/64	0.06	0	1500	1500	1500	140	8262R099 ⑤	1	●	-	-	-	-	2	
1/8	3/32	0.21	0	720	410	410	180	8262R277	1	○	8262R178	1	○	-	2	
1/8	1/8	0.35	0	540	395	360	180	8262R105	1	○	8262R174	1	○	-	2	
1/8	1/8	0.35	0	200	-	-	167	8262R077 ⑥	1	○	-	-	-	-	2	
1/4	3/64	0.06	0	1500	1500	1500	140	8262R107 ⑤	2	●	-	-	-	-	2	
1/4	3/64	0.06	0	2200	2200	1700	140	-	-	-	8262R181 ⑤	2	●	-	2	
1/4	3/32	0.21	0	720	410	410	180	8262R109	2	○	8262R183	2	○	-	2	
1/4	1/8	0.35	0	540	395	360	180	8262R232	2	○	8262R185	2	○	-	2	
1/4	5/32	0.52	0	300	225	225	180	8262R202	2	○	8262R220	2	○	-	2	
1/4	7/32	0.73	0	125	125	125	180	8262R208	2	○	8262R226	2	○	-	2	
1/4	9/32	0.88	0	105	105	105	180	8262R212	2	○	8262R230	2	○	-	2	
1/4	9/32	1.0	0	50	-	-	167	8262R078 ⑥	2	○	-	-	-	-	2	
1/4	5/16	1.5	10	1500	1500	1500	180	8223P025	18	-	-	-	-	-	2	
3/8	1/8	0.35	0	540	395	360	180	8263R115	3	○	8263R191	3	○	-	2	
3/8	5/32	0.52	0	300	225	225	180	8263R200	3	○	8263R193	3	○	-	2	
3/8	7/32	0.73	0	125	125	125	180	8263R124	3	○	8263R332	3	○	-	2	
3/8	9/32	0.88	0	105	85	85	180	8263R210	3	○	8263R333	3	○	-	2	
3/8	5/16	1.5	10	1500	1500	1500	180	8223P027	18	-	-	-	-	-	2	
3/8	5/8	3	0	150	150	-	180	8210P093	4	○	-	-	-	-	2	
3/8	5/8	3	5	300	300	300	180	8210P006	4	●	-	-	-	-	2	
1/2	3/8	3.2	25	1500	1500	1500	180	8223P003	5	-	8223P010	6	-	-	2	
1/2	5/8	4	0	150	150	-	180	8210P094	4	○	-	-	-	-	2	
1/2	5/8	4	0	150	150	125	180	-	-	-	8210P087	7	●	-	2	
1/2	5/8	4	5	300	300	300	180	8210P007	4	○	-	-	-	-	2	
3/4	5/8	4.5	0	150	150	125	180	-	-	-	8210P088	7	●	-	2	
3/4	3/4	5	0	150	150	-	180	8210P095	7	○	-	-	-	-	2	
3/4	3/4	5	0	3	3	-	180	8030P003	8	○	-	-	-	-	2	
3/4	3/4	7.8	25	750	750	750	180	8223P005	9	-	-	-	-	-	2	
1	1	13	5	150	150	100	180	8210P004	10	○	-	-	-	-	2	
1 1/4	1 1/8	15	5	150	150	100	180	8210P008	10	○	-	-	-	-	2	
1 1/2	1 1/4	22.5	5	150	150	100	180	8210P022	11	○	-	-	-	-	2	
2	1 3/4	43	5	150	125	90	180	8210P100	12	●	-	-	-	-	2	
<b>General Service - Normally Open</b>																
1/8	3/64	0.06	0	1150	900	800	140	8262R155 ⑤	1	●	8262R168 ⑤	1	●	-	2	
1/8	3/64	0.06	0	750	750	750	180	8262R156	1	●	8262R169	1	●	-	2	
1/8	3/32	0.21	0	275	230	180	180	8262R128	1	●	8262R236	1	●	-	2	
1/8	1/8	0.35	0	160	145	125	180	8262R129	1	●	8262R237	1	●	-	2	
1/4	3/64	0.06	0	1150	900	800	140	8262R161 ⑤	2	●	8262R199 ⑤	2	●	-	2	
1/4	3/64	0.06	0	750	750	750	180	8262R260	2	●	8262R130	2	●	-	2	
1/4	3/32	0.21	0	275	230	180	180	8262R261	2	●	8262R134	2	●	-	2	
1/4	1/8	0.35	0	160	145	125	180	8262R262	2	●	8262R138	2	●	-	2	
1/4	5/32	0.54	0	90	90	70	180	8262R263	2	●	8262R142	2	●	-	2	
1/4	7/32	0.83	0	45	45	40	180	8262R264	2	●	8262R148	2	●	-	2	
1/4	9/32	0.96	0	30	30	30	180	8262R265	2	●	8262R152	2	●	-	2	
3/8	1/8	0.35	0	160	145	125	180	8263R070	3	●	8263R080	3	●	-	2	
3/8	5/32	0.54	0	90	90	70	180	8263R071	3	●	8263R081	3	●	-	2	
3/8	7/32	0.83	0	45	45	40	180	8263R072	3	●	8263R082	3	●	-	2	
3/8	9/32	0.96	0	30	30	30	180	8263R073	3	●	8263R083	3	●	-	2	
3/8	5/8	3	0	150	150	125	180	8210P033	15	●	-	-	-	-	2	
1/2	5/8	4	0	150	150	125	180	8210P034	15	●	-	-	-	-	2	
3/4	3/4	5.5	0	150	150	125	180	8210P035	16	●	-	-	-	-	2	
3/4	3/4	5.5	0	2	2	-	180	8030P083	17	●	-	-	-	-	2	

○ = Safety Shut-off Valve. ● = General Purpose Valve.

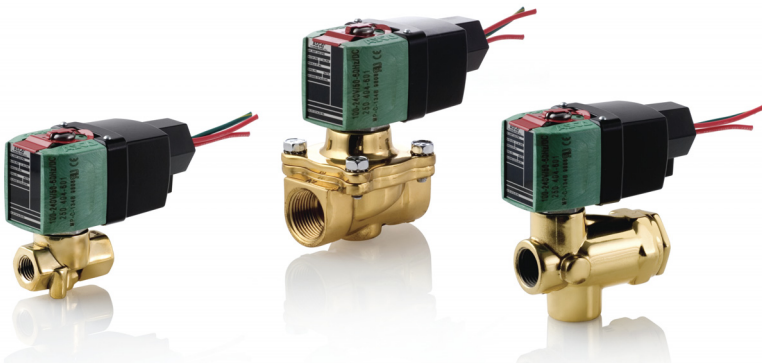

Pipe Size (in)	Orifice Dia. (in)	Base Catalog Number		Resilient Materials and Suffix Options													Other		Standard Rebuild Kit		
		Brass	Stainless Steel	Ammonia ⑦	Silicone Free	Dry Air	NBR	LT NBR	FKM	EPDM	CR	Oxygen Service	PTFE ②	Urethane	Vacuum	Manual Operator	Mounting Bracket	Brass AC/DC	Stainless Steel AC/DC		
1/8	3/64	8262R099 ⑤	8262R175 ⑤	-	SF	-	-	-	-	-	-	-	-	-	-	●	-	-	MB	323593-W	323595-W
1/8	3/64	8262R155 ⑤	8262R168 ⑤	-	SF	-	-	-	-	-	-	-	-	-	-	●	-	-	MB	323986-W	323988-W
1/8	3/64	8262R156	8262R169	NH	SF	-	●	A	V	E	J	N	T	-	-	-	-	MS	MB	323986	323988
1/8	3/32	8262R277	8262R178	NH	SF	-	●	A	V	E	J	N	T	-	-	-	-	MS	MB	323593	323595
1/8	3/32	8262R128	8262R236	NH	SF	-	●	A	V	E	J	N	T	-	-	-	-	MS	MB	323987	323989
1/8	1/8	8262R105	8262R174	NH	SF	-	●	A	V	E	J	N	T	-	-	VH	-	MS	MB	323593	323595
1/8	1/8	8262R077 ⑥	-	-	SF	-	-	●	-	-	-	-	-	-	-	-	-	-	MB	325039	-
1/8	1/8	8262R129	8262R237	NH	SF	-	●	A	V	E	J	N	T	-	-	VH	-	MS	MB	323987	323989
1/4	3/64	8262R107 ⑤	8262R181 ⑤	-	-	-	-	-	-	-	-	-	-	-	-	●	-	-	MB	323593-W	323595-W
1/4	3/64	8262R161 ⑤	8262R199 ⑤	-	SF	-	-	-	-	-	-	-	-	-	-	●	-	-	MB	323986-W	323988-W
1/4	3/64	8262R260	8262R130	NH	SF	-	●	A	V	E	J	N	T	-	-	-	-	MS	MB	323986	323988
1/4	3/32	8262R109	8262R183	NH	SF	P	●	A	V	E	J	N	T	-	-	-	-	MS	MB	323593	323595
1/4	3/32	8262R261	8262R134	NH	SF	-	●	A	V	E	J	N	T	-	-	-	-	MS	MB	323987	323989
1/4	1/8	8262R232	8262R184	NH	SF	P	●	A	V	E	J	N	T	-	-	-	-	MS	MB	323593	323595
1/4	1/8	8262R262	8262R138	NH	SF	-	●	A	V	E	J	N	T	-	-	-	-	MS	MB	323987	323989
1/4	5/32	8262R202	8262R220	NH	SF	P	●	A	V	E	J	N	T	-	-	-	-	MS	MB	323593	323595
1/4	5/32	8262R263	8262R142	NH	SF	-	●	A	V	E	J	N	T	-	-	-	-	MS	MB	323987	323989
1/4	7/32	8262R208	8262R226	NH	SF	P	●	A	V	E	J	N	T	-	-	-	-	MS	MB	323593	323595
1/4	7/32	8262R264	8262R148	NH	SF	-	●	A	V	E	J	N	T	-	-	-	-	MS	MB	323987	323989
1/4	9/32	8262R212	8262R230	NH	SF	P	●	A	V	E	J	N	T	-	-	VH	-	MS	MB	323593	323595
1/4	9/32	8262R265	8262R152	NH	SF	-	●	A	V	E	J	N	T	-	-	VH	-	MS	MB	323987	323989
1/4	9/32	8262R078 ⑥	-	-	SF	-	-	●	-	-	-	-	-	-	-	-	-	-	MB	325039	-
1/4	5/16	8223P025 ④	-	-	-	-	●	A	-	-	-	-	-	-	-	-	-	-	-	322815	-
3/8	1/8	8263R115	8263R191	NH	SF	-	●	A	V	E	J	N	T	-	-	-	-	MS	MB	323593	323595
3/8	1/8	8263R070	8263R080	NH	SF	-	●	A	V	E	J	N	T	-	-	-	-	MS	MB	323987	323989
3/8	5/32	8263R200	8263R193	NH	SF	-	●	A	V	E	J	N	T	-	-	-	-	MS	MB	323593	323595
3/8	5/32	8263R071	8263R081	NH	SF	-	●	A	V	E	J	N	T	-	-	-	-	MS	MB	323987	323989
3/8	7/32	8263R124	8263R332	NH	SF	-	●	A	V	E	J	N	T	-	-	-	-	MS	MB	323593	323595
3/8	7/32	8263R072	8263R082	NH	SF	-	●	A	V	E	J	N	T	-	-	-	-	MS	MB	323987	323989
3/8	9/32	8263R210	8263R333	NH	SF	-	●	A	V	E	J	N	T	-	-	-	-	MS	MB	323593	323595
3/8	9/32	8263R073	8263R083	NH	SF	-	●	A	V	E	J	N	T	-	-	-	-	MS	MB	323987	323989
3/8	5/16	8223P027 ④	-	-	-	-	●	-	-	-	-	-	-	-	-	-	-	-	-	322815	-
3/8	5/8	8210P093	-	-	-	-	●	-	V	E	J	N	-	-	VH	-	MO	MB	322670	-	
3/8	5/8	8210P033	-	-	-	-	●	-	V	E	J	N	-	-	VH	-	MO	MB	322770	-	
3/8	5/8	8210P006	-	-	-	-	●	-	V	E	J	N	-	-	-	-	MO	MB	322654	-	
1/2	3/8	8223P003 ④	8223P010 ①	-	-	-	●	-	-	-	-	-	-	-	-	-	-	-	-	322816	322817
1/2	5/8	8210P094	-	-	-	-	●	-	V	E	J	N	-	-	VH	-	MO	MB	322670	-	
1/2	5/8	8210P034	-	-	-	-	●	-	V	E	J	N	-	-	VH	-	MO	MB	322770	-	
1/2	5/8	-	8210P087	-	-	-	●	-	V	E	J	N	-	-	-	-	MO	MB	-	322676	-
1/2	5/8	8210P007	-	-	-	-	●	-	V	E	J	N	-	-	-	-	MO ③	MB	322654	-	
3/4	5/8	-	8210P088	-	-	-	●	-	V	E	J	N	-	-	-	-	MO	MB	-	322676	-
3/4	3/4	8210P095	-	-	-	-	●	-	V	E	J	N	-	-	VH	-	MO	MB	322673	-	
3/4	3/4	8030P003	-	-	-	-	●	-	V	E	J	N	-	-	-	-	MO	MB	322758	-	
3/4	3/4	8210P035	-	-	-	-	●	-	V	E	J	N	-	-	VH	-	MO	MB	322771	-	
3/4	3/4	8030P083	-	-	-	-	●	-	V	E	J	N	-	-	-	-	MO	MB	322763	-	
3/4	3/4	8223P005 ④	-	-	-	-	●	-	-	-	-	-	-	-	-	-	-	-	-	322818	-
1	1	8210P004	-	-	-	-	●	-	V	E	J	N	-	-	-	-	MO	MB	322677	-	
1 1/4	1 1/8	8210P008	-	-	-	-	●	-	V	E	J	N	-	-	-	-	MO	MB	322680	-	
1 1/2	1 1/4	8210P022	-	-	-	-	●	-	V	E	J	N	-	-	-	-	MO	MB	322680	-	
2	1 3/4	8210P100	-	-	-	-	●	-	V	E	J	N	-	-	-	-	MO	MB	322682	-	

● = Standard. Other options may be available. All option combinations may not be available. Please consult your local ASCO contact.  
 ① Valve contains PTFE main disc; ② Pressure rating reduced by 25%; ③ Pressure rating limited to 250 psi; ④ Valve contains Nylon 11 piston.  
 ⑤ Cast UR disc supplied as standard, limits min. ambient temp. to 32°F (0°C). ⑥ Fuel gas service only; Ambient Temp. -40°F to 140°F; Fluid Temp. -40°F to 167°F; Gas capacity for 8262R077 is 18,700 Btu/hr, for 8262R078 53,500 Btu/hr based on 1" W.C. Drop @ 2" W.C. Inlet Pressure, 1000 Btu/cu.ft. or more, 0.64 Specific Gravity Gas.  
 ⑦ NH suffix only available for Stainless Steel constructions. ⑧ Water rating, CSA certified up to 232 psi.

Dimensions: inches

Const. Ref.	B	C	D	E	F	G	H	I
1	3.98	3.04	2.00	0.69	1.00	1.19	1.87	1.24
2	3.98	3.04	2.00	0.78	1.11	1.56	1.87	1.29
3	3.98	3.04	2.00	0.77	1.20	1.88	1.87	1.25
4	3.98	3.04	2.00	1.28	1.84	2.75	1.87	2.28
5	3.98	3.04	2.00	1.05	2.31	-	1.87	3.03
6	3.98	3.04	2.00	1.13	2.31	-	1.87	3.13
7	3.98	3.04	2.00	1.46	2.19	2.81	1.87	2.28
8	3.98	3.04	2.00	1.44	2.13	2.81	1.87	2.28
9	3.98	3.04	2.00	1.61	3.03	-	1.87	3.6
10	3.98	3.04	2.00	2.21	3.67	3.75	1.87	-
11	3.98	3.04	2.00	2.36	4.14	4.38	1.87	3.92
12	3.98	3.04	2.00	2.75	5.52	5.06	1.87	4.72
15	3.98	3.04	2.00	1.72	2.18	2.75	1.87	2.28
16	3.98	3.04	2.00	1.88	2.57	2.81	1.87	2.28
17	3.98	3.04	2.00	0.85	1.81	2.81	1.87	2.28
18	3.98	3.04	2.00	0.77	1.20	1.88	1.87	1.25

Const. Ref. 1

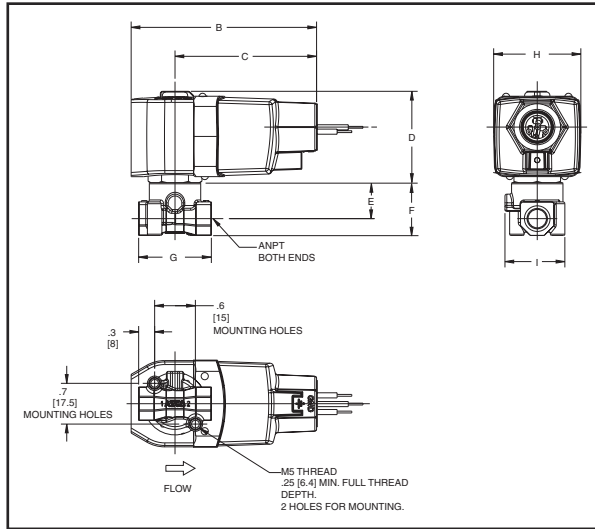

Const. Ref. 2

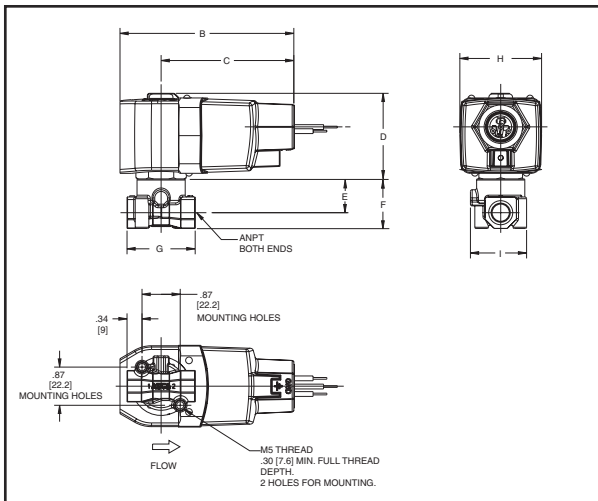

Const. Ref. 3

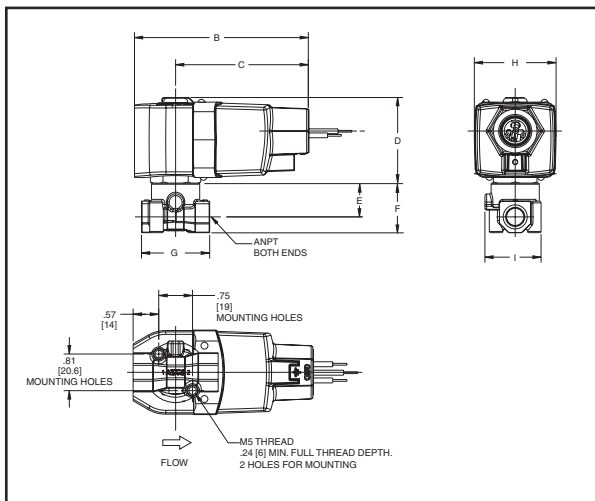

Const. Ref. 4, 7, 15, 16, 17

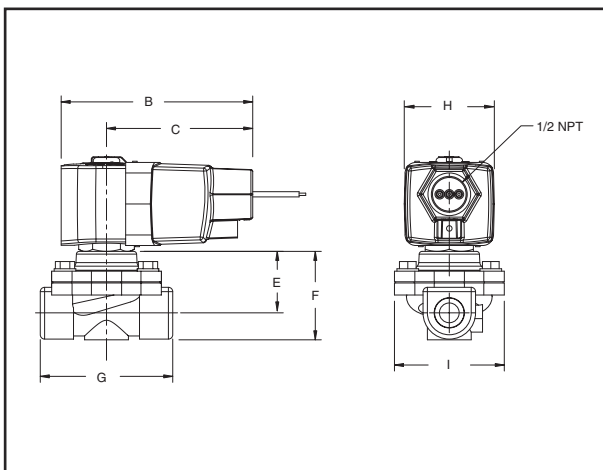

Const. Ref. 5, 6, 9

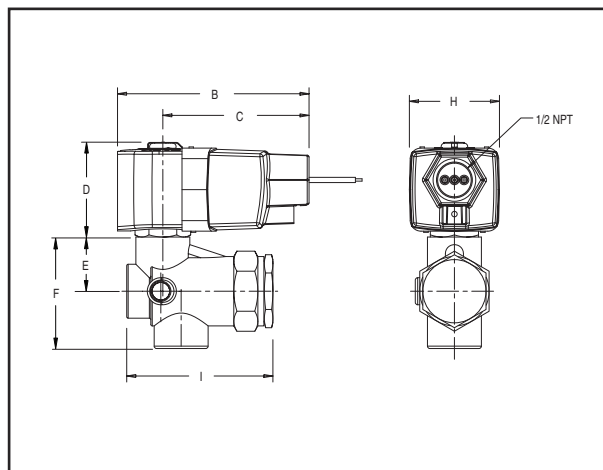



Dimensions: inches

Const. Ref. 8

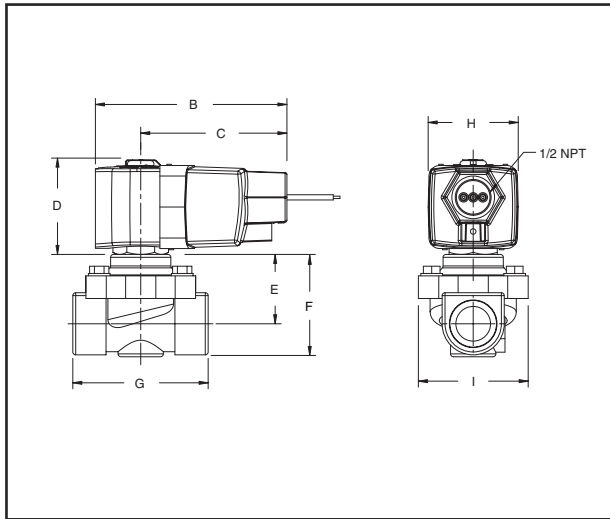

Const. Ref. 10

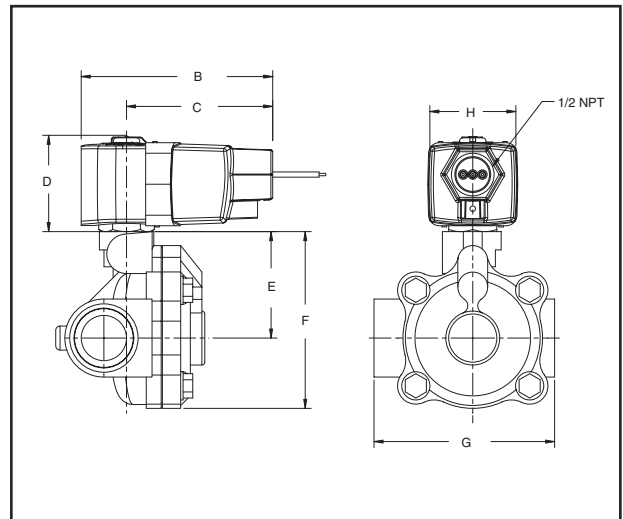

Const. Ref. 11, 12

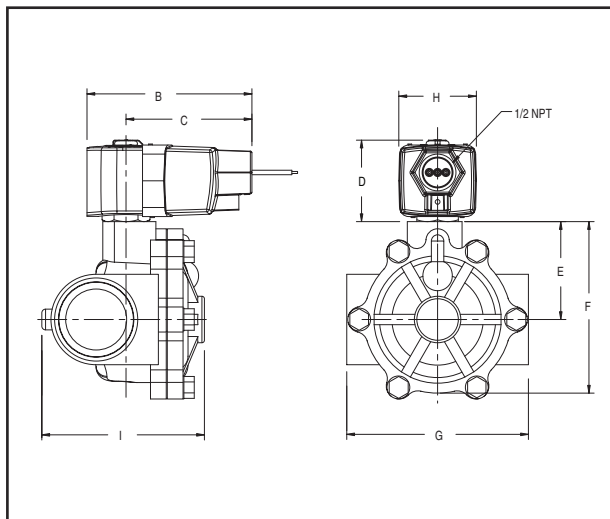

Const. Ref. 18

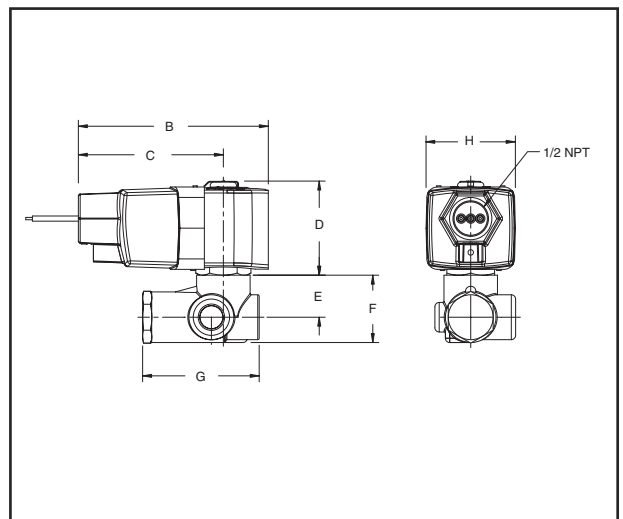

- Three-way (3/2) Next Generation solenoid valves have three ports and two orifices. When one orifice is AC open, the other is closed.
- Control of air, water, light oil, and other non-corrosive media.
- Normally closed (pressure to cylinder port when energized) operation.
- Normally open (cylinder port exhausts when energized) operation.
- Universal operation (can function as normally open, normally closed, diverter of fluid flow, or selector of 2 fluid sources configurable by piping).
- Pipe sizes – 1/4 to 3/4 inch.



Specifications

Pipe Size (in)	Orifice Dia. (in)	Cv Flow	Operating Pressure Differential (psi)				Max. Fluid Temp. °F	Brass	Const. Ref.	Agency		Const. Ref.	Agency		Wattage AC/DC	Approx. Shipping Weight (lbs.)
			Min.	Max. AC/DC						UL	Stainless Steel		UL			
				Air-Inert Gas	Water ⑧	Light Oil @ 300 SSU										
<b>General Service - Normally Closed</b>																
1/8	3/64	0.05 ③	0	300	300	300 ⑦	200 ⑥	8314R031	1	●	8314R037	1	●	2	1.7	
1/8	3/32	0.15 ④	0	205	205	190 ⑦	200 ⑥	8314R032	1	●	8314R038	1	●	2	1.7	
1/8	1/8	0.25 ④	0	145	145	100 ⑦	200 ⑥	8314R033	1	●	8314R039	1	●	2	1.7	
1/4	3/64	0.05 ③	0	300	300	300 ⑦	200 ⑥	8314R034	2	●	8314R068	2	●	2	1.8	
1/4	3/32	0.15 ④	0	205	205	190 ⑦	200 ⑥	8314R035	2	●	8314R121	2	●	2	1.8	
1/4	1/8	0.25 ④	0	145	145	100 ⑦	200 ⑥	8314R036	2	●	8314R126	2	●	2	1.8	
1/4	5/32	0.50 ④	0	75	75	75 ⑦	200 ⑥	8314R130	2	●	8314R230	2	●	2	1.8	
1/4	7/32	0.70 ④	0	40	40	40 ⑦	200 ⑥	8314R131	2	●	8314R231	2	●	2	1.8	
1/4	9/32	0.85 ④	0	25	25	25 ⑦	200 ⑥	8314R132	2	●	8314R232	2	●	2	1.8	
1/4	5/64	0.12	0	232	232	232	180	8320P182	3	●	-	-	-	2	2.5	
1/4	7/64	0.23	0	150	150	150	180	8320P184	3	●	-	-	-	2	2.5	
1/4	5/32	0.35	0	75	75	75	180	8320P186	3	●	-	-	-	2	2.5	
1/4	3/32 ①	0.2 ①	5 ⑤	150	150	100	180	8317P035	4	●	-	-	-	2	2.7	
1/4	9/32 ②	0.8 ②	10	200	200	200	180	8321P001	5	●	-	-	-	2	3.8	
3/8	9/32 ②	0.8 ②	10	200	200	200	180	8321P002	5	●	-	-	-	2	3.8	
3/8	5/8	2.5	10	250	250	-	180	8316P054	6	●	-	-	-	2	4.9	
1/2	5/8	3.2	10	250	250	-	180	8316P064	6	●	-	-	-	2	4.9	
3/4	11/16	4.8	10	250	250	-	180	8316P074	7	●	-	-	-	2	5.1	
<b>NAMUR Mount - 3/2 Normally Closed</b>																
1/4	3/32	0.12	-	150	-	-	180	8320P704	9	●	8320P714	9	●	2	3.2	
<b>General Service - Normally Open</b>																
1/8	3/64	0.05 ③	0	300	300	300 ⑦	200 ⑥	8314R049	1	●	8314R055	1	●	2	1.7	
1/8	3/32	0.15 ④	0	175	175	175 ⑦	200 ⑥	8314R050	1	●	8314R056	1	●	2	1.7	
1/8	1/8	0.25 ④	0	160	160	160 ⑦	200 ⑥	8314R051	1	●	8314R057	1	●	2	1.7	
1/4	3/64	0.05 ③	0	300	300	300 ⑦	200 ⑥	8314R052	2	●	8314R069	2	●	2	1.8	
1/4	3/32	0.15 ④	0	175	175	175 ⑦	200 ⑥	8314R053	2	●	8314R122	2	●	2	1.8	
1/4	1/8	0.25 ④	0	160	160	160 ⑦	200 ⑥	8314R054	2	●	8314R070	2	●	2	1.8	
1/4	5/32	0.50 ④	0	150	150	150 ⑦	200 ⑥	8314R133	2	●	8314R233	2	●	2	1.8	
1/4	7/32	0.70 ④	0	100	100	100 ⑦	200 ⑥	8314R134	2	●	8314R234	2	●	2	1.8	
1/4	9/32	0.85 ④	0	65	65	65 ⑦	200 ⑥	8314R135	2	●	8314R235	2	●	2	1.8	
1/8	3/64	0.18	-	350	350	350	180	8320P136	8	●	8320P146	8	●	2	2.5	
1/4	1/32	0.05	-	790	825	825	180	8320P190	3	●	-	-	-	2	2.5	
1/4	5/64	0.12	0	210	210	210	180	8320P192	3	●	-	-	-	2	2.5	
1/4	7/64	0.23	0	150	150	150	180	8320P194	3	●	-	-	-	2	2.5	
<b>General Service - Universal Operation</b>																
1/8	3/64	0.05 ③	0	200	200	200 ⑦	200 ⑥	8314R041	1	●	8314R042	1	●	2	1.7	
1/8	3/32	0.15 ④	0	105	85	60 ⑦	200 ⑥	8314R043	1	●	8314R044	1	●	2	1.7	
1/8	1/8	0.25 ④	0	70	70	40 ⑦	200 ⑥	8314R045	1	●	8314R040	1	●	2	1.7	
1/4	3/64	0.05 ③	0	200	200	200 ⑦	200 ⑥	8314R006	2	●	8314R123	2	●	2	1.8	
1/4	3/32	0.15 ④	0	105	85	60 ⑦	200 ⑥	8314R007	2	●	8314R120	2	●	2	1.8	
1/4	1/8	0.25 ④	0	70	70	40 ⑦	200 ⑥	8314R008	2	●	8314R124	2	●	2	1.8	
1/4	5/32	0.50 ④	0	35	35	35 ⑦	200 ⑥	8314R127	2	●	8314R227	2	●	2	1.8	
1/4	7/32	0.70 ④	0	18	18	18 ⑦	200 ⑥	8314R128	2	●	8314R228	2	●	2	1.8	
1/4	9/32	0.85 ④	0	10	10	10 ⑦	200 ⑥	8314R129	2	●	8314R229	2	●	2	1.8	
1/4	5/64	0.12	0	116	116	116	180	8320P172	3	●	-	-	-	2	2.5	
1/4	7/64	0.23	0	60	60	60	180	8320P174	3	●	-	-	-	2	2.5	
1/4	5/32	0.35	0	35	35	35	180	8320P176	3	●	-	-	-	2	2.5	

● = General Purpose Valve. ① 1/4" exhaust orifice with 0.73 Cv flow; ② 11/32" exhaust orifice with 1.20 Cv flow; ③ 3/64" exhaust orifice with 0.06 Cv flow. ④ 3/32" exhaust orifice with 0.20 Cv flow. ⑤ 10 psi minimum for light oils. ⑥ Max. fluid temp. 180°F for light oil @ 45 SSU. ⑦ Pressure rating for light oil @ 45 SSU. ⑧ Water rating, CSA certified up to 232 psi.

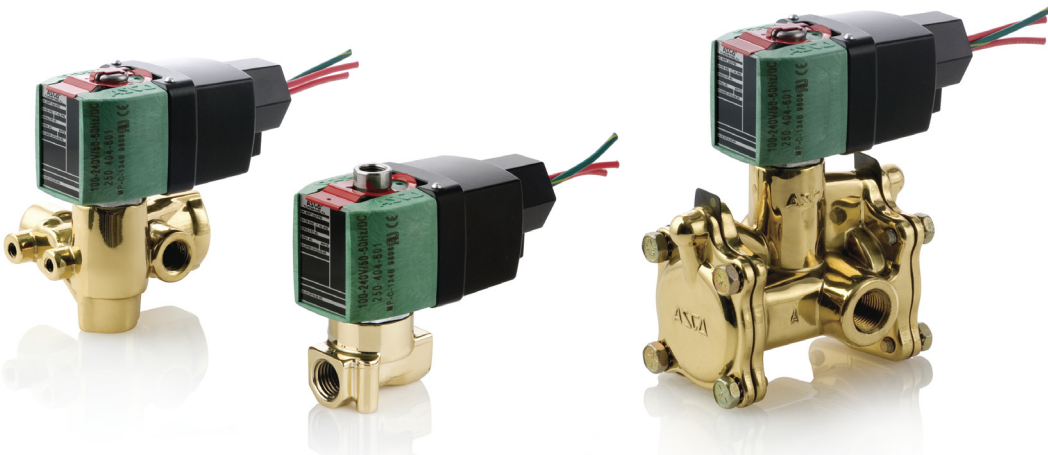

**Optional Features Chart**

Pipe Size (in)	Orifice Dia. (in)	Base Catalog Number		Resilient Materials and Suffix Options										Other		Standard Rebuild Kit	
		Brass	Stainless Steel	Silicone Free	NBR	FKM	EPDM	CR	Oxygen Service	PTFE ①	Urethane	Vacuum	Manual Operator ③	Mounting Bracket	Brass AC/DC	Stainless Steel AC/DC	
1/8	3/64	8314R031	8314R037	SF	●	V ②	-	-	N	-	-	-	MS	MB	323957	323959	
1/8	3/64	8314R041	8314R042	SF	●	V ②	-	-	N	-	-	-	MS	MB	323961	323963	
1/8	3/64	8314R049	8314R055	SF	●	V ②	-	-	N	-	-	-	MS	MB	323969	323971	
1/8	3/32	8314R032	8314R038	SF	●	V ②	-	-	N	-	-	-	MS	MB	323958	323960	
1/8	3/32	8314R043	8314R044	SF	●	V ②	-	-	N	-	-	-	MS	MB	323966	323968	
1/8	3/32	8314R050	8314R056	SF	●	V ②	-	-	N	-	-	-	MS	MB	323970	323972	
1/8	1/8	8314R033	8314R039	SF	●	V ②	-	-	N	-	-	-	MS	MB	323958	323960	
1/8	1/8	8314R045	8314R040	SF	●	V ②	-	-	N	-	-	-	MS	MB	323966	323968	
1/8	1/8	8314R051	8314R057	SF	●	V ②	-	-	N	-	-	-	MS	MB	323970	323972	
1/8	7/16	8320P136	8320P146	⑤	●	V	E	J	N	T	-	-	MO/MS	MB	322715	322718	
1/4	1/32	8320P190	-	⑤	●	V	E	J	N	T	-	-	MO/MS	MB	322744	-	
1/4	3/64	8314R006	8314R123	SF	●	V ②	-	-	N	-	-	-	MS	MB	323961	323963	
1/4	3/64	8314R034	8314R068	SF	●	V ②	-	-	N	-	-	-	MS	MB	323957	323959	
1/4	3/64	8314R052	8314R069	SF	●	V ②	-	-	N	-	-	-	MS	MB	323969	323971	
1/4	5/64	8320P172	-	⑤	●	V	E	J	N	T	-	-	MO/MS ④	MB	322721	-	
1/4	5/64	8320P182	-	⑤	●	V	E	J	N	T	-	-	MO/MS	MB	322722	-	
1/4	5/64	8320P192	-	⑤	●	V	E	J	N	T	-	-	MO/MS ④	MB	322723	-	
1/4	3/32	8314R007	8314R120	SF	●	V ②	-	-	N	-	-	-	MS	MB	323966	323968	
1/4	3/32	8314R035	8314R121	SF	●	V ②	-	-	N	-	-	-	MS	MB	323958	323960	
1/4	3/32	8314R053	8314R122	SF	●	V ②	-	-	N	-	-	-	MS	MB	323970	323972	
1/4	3/32	8317P035	-	⑤	●	V	-	-	N	-	-	-	-	-	322919	-	
1/4	3/32	8320P704	8320P714	⑤	●	V	E	J	N	T	-	-	MO/MS	-	322821	322823	
1/4	7/64	8320P174	-	⑤	●	V	E	J	N	T	-	-	MO/MS ④	MB	322721	-	
1/4	7/64	8320P184	-	⑤	●	V	E	J	N	T	-	-	MO/MS	MB	322722	-	
1/4	7/64	8320P194	-	⑤	●	V	E	J	N	T	-	-	MO/MS ④	MB	322723	-	
1/4	1/8	8314R008	8314R124	SF	●	V ②	-	-	N	-	-	-	MS	MB	323966	323968	
1/4	1/8	8314R036	8314R126	SF	●	V ②	-	-	N	-	-	-	MS	MB	323958	323960	
1/4	1/8	8314R054	8314R070	SF	●	V ②	-	-	N	-	-	-	MS	MB	323970	323972	
1/4	5/32	8314R127	8314R227	SF	●	V ②	-	-	N	-	-	-	MS	MB	323966	323968	
1/4	5/32	8314R130	8314R230	SF	●	V ②	-	-	N	-	-	-	MS	MB	323958	323960	
1/4	5/32	8314R133	8314R233	SF	●	V ②	-	-	N	-	-	-	MS	MB	323970	323972	
1/4	5/32	8320P176	-	⑤	●	V	E	J	N	T	-	-	MO/MS ④	MB	322721	-	
1/4	5/32	8320P186	-	⑤	●	V	E	J	N	T	-	-	MO/MS	MB	322722	-	
1/4	7/32	8314R128	8314R228	SF	●	V ②	-	-	N	-	-	-	MS	MB	323966	323968	
1/4	7/32	8314R131	8314R231	SF	●	V ②	-	-	N	-	-	-	MS	MB	323958	323960	
1/4	7/32	8314R134	8314R234	SF	●	V ②	-	-	N	-	-	-	MS	MB	323970	323972	
1/4	9/32	8314R129	8314R229	SF	●	V ②	-	-	N	-	-	-	MS	MB	323966	323968	
1/4	9/32	8314R132	8314R232	SF	●	V ②	-	-	N	-	-	-	MS	MB	323958	323960	
1/4	9/32	8314R135	8314R235	SF	●	V ②	-	-	N	-	-	-	MS	MB	323970	323972	
1/4	9/32	8321P001	-	⑤	●	V	E	-	-	-	-	-	MO/MS	-	322688	-	
3/8	9/32	8321P002	-	⑤	●	V	E	-	-	-	-	-	MO/MS	-	322688	-	
3/8	5/8	8316P054	-	⑤	●	V	E	J	N	-	-	-	MO	MB	322690	-	
1/2	5/8	8316P064	-	⑤	●	V	E	J	N	-	-	-	MO	MB	322690	-	
3/4	11/16	8316P074	-	⑤	●	V	E	J	N	-	-	-	MO	MB	322692	-	

● = Standard. Other options may be available. All option combinations may not be available. Please consult your local ASCO contact. ③ Pressure rating reduced by 25%.  
② Upper disc is FKM. ③ Not available with PTFE resilient materials. ④ Pressure rating limited to 100 psi (6.9 bar) for MO constructions. ⑤ Consult factory.

Dimensions: inches

Const. Ref.	B	C	D	E	F	G	H	I	J
1	3.98	3.04	2.09	0.69	1.00	1.19	1.87	1.24	-
2	3.98	3.04	2.09	0.79	1.19	1.56	1.87	1.29	-
3	3.98	3.04	2.00	1.02	2.02	1.69	1.87	1.45	0.44
4	3.98	3.04	2.00	0.57	1.07	2.00	1.87	2.05	-
5	3.98	3.04	2.00	1.00	2.03	1.31	1.87	3.12	1.00
6	3.98	3.04	2.00	2.12	3.77	2.76	1.87	4.29	-
7	3.98	3.04	2.00	2.5	4.19	-	1.87	3.38	-
8	3.98	3.04	2.00	0.67	1.64	1.19	1.87	-	1.81

Const. Ref. 1, 2

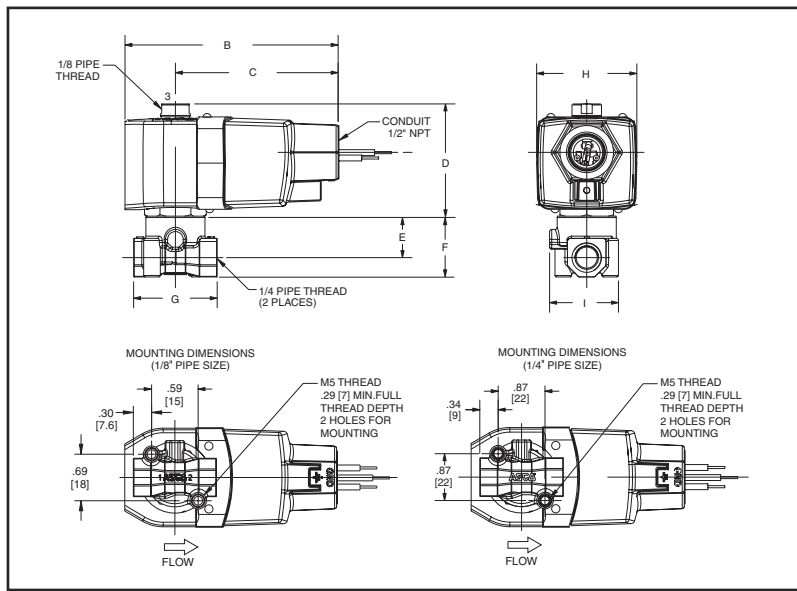

Const. Ref. 3

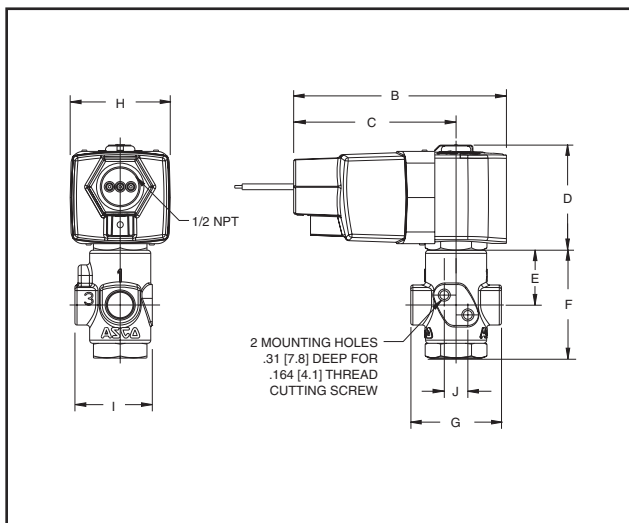

Const. Ref. 4

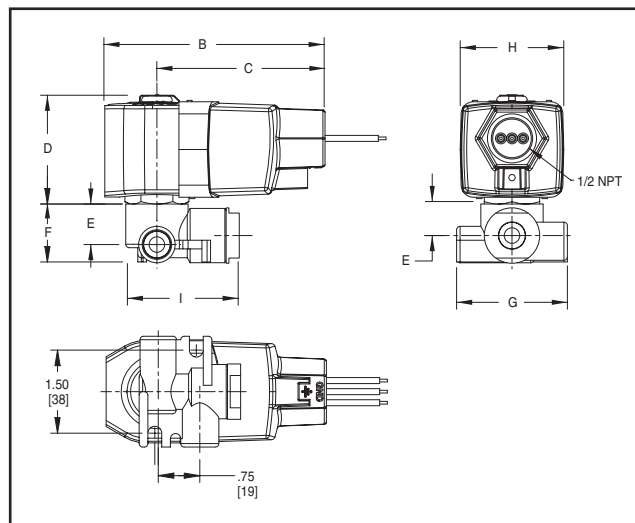

Dimensions: inches

Const. Ref. 5

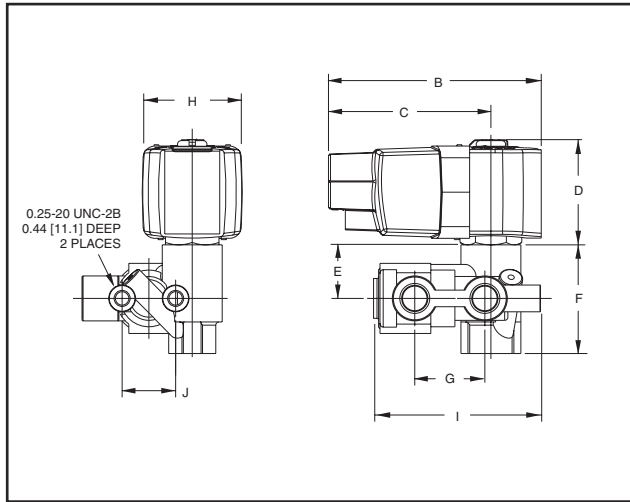

Const. Ref. 6

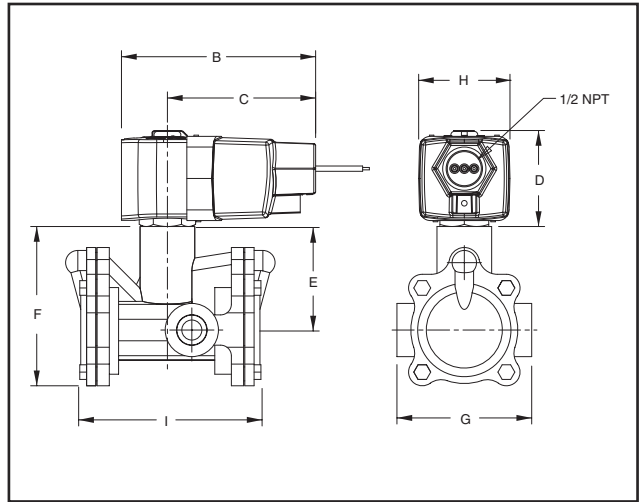

Const. Ref. 7

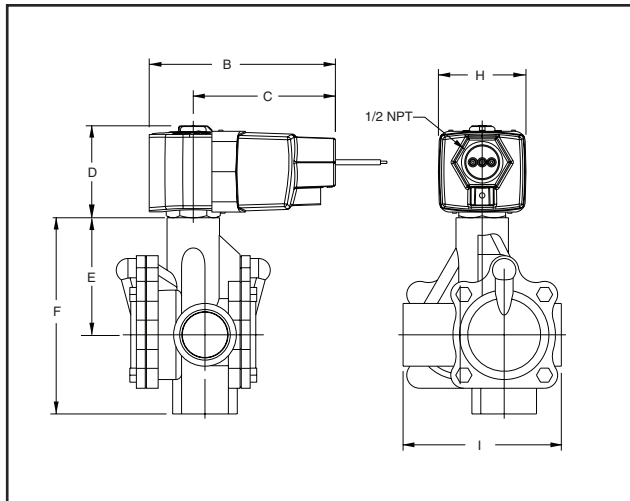

Const. Ref. 8

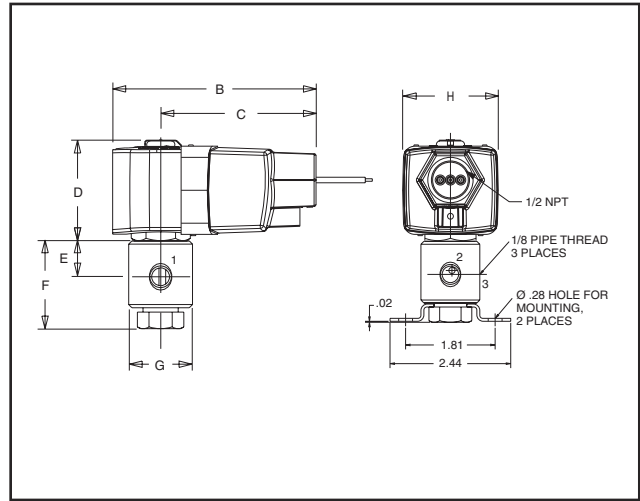

Const. Ref. 9

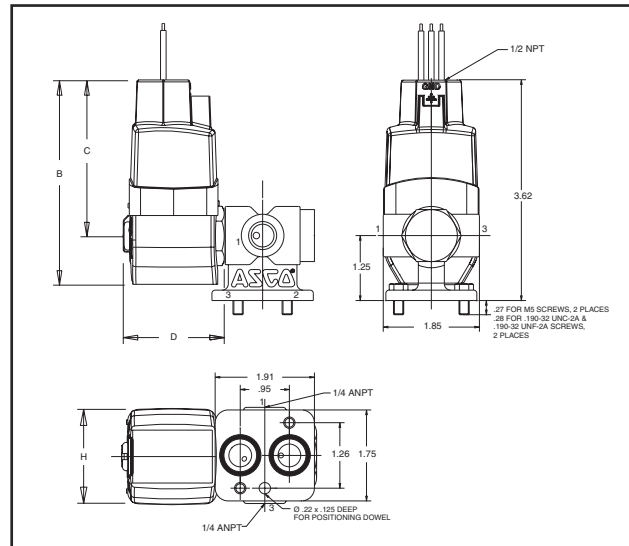

- Four-way, four port (4/2) and five port (5/2) Next Generation solenoid valves have one pressure port, 2 cylinder ports, and either 1 or 2 exhaust ports.
- Control of air, water, light oil, and non-corrosive media.
- Single solenoid operation (pressure and exhaust ports and cylinder ports alternate connection based on solenoid operation).
- Pipe sizes – 1/4 to 1 inch.

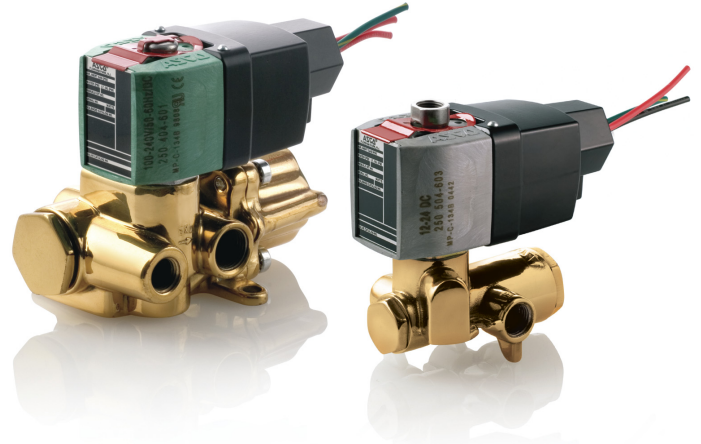

### Specifications

Pipe Size (in)	Orifice Dia. (in)	Cv Flow		Operating Pressure Differential (psi)			Max. Fluid Temp. °F	Brass	Const. Ref.	Agency UL	316L Stainless Steel	Const. Ref.	Agency UL	Wattage AC/DC	
				Min.	Max. AC/DC										
		Pressure	Exhaust		Air-Inert Gas	Water ⑤									Light Oil @ 300 SSU
<b>General Service - Single Solenoid</b>															
1/4	1/16 ②	0.09	0.09	10	150	150	150 ③	180	8345P001	1	●	-	-	-	2
1/4	1/4	0.8	1.0	10 ①	250	250	250	180	8344P070	2	●	-	-	-	2
3/8	3/8	1.4	2.2	10 ①	250	250	250	180	8344P072	3	●	-	-	-	2
1/2	3/8	1.4	2.2	10 ①	250	250	250	180	8344P074	3	●	-	-	-	2
3/4	3/4	5.2	5.6	10 ①	250	250	250	180	8344P076	4	●	-	-	-	2
1	3/4	5.2	5.6	10 ①	250	250	250	180	8344P078	4	●	-	-	-	2
<b>General Service - 4/2 Dual Solenoid</b>															
3/8	3/8	1.4	2.2	10 ①	300	300	200	180	8344P080	5	●	-	-	-	2
<b>NAMUR Mount - 3/2, 5/2 Single Solenoid</b>															
1/4	1/4	0.86	0.86	30	150	-	-	180	EE8551P401 ④	6	●	EE8551P409	6	●	2

● = General Purpose Valve. ① 25 psi minimum for light oils. ② 3/32" exhaust orifice. ③ Viscosity 50 SSU max. ④ Aluminum body. ⑤ Water rating, CSA certified up to 232 psi.

### Optional Features Chart

Pipe Size (in)	Orifice Dia. (in)	Base Catalog Number		Resilient Materials and Suffix Options								Other		Standard Rebuild Kit	
		Brass	316L Stainless Steel	NBR	FKM	EPDM	CR	Oxygen Service	PTFE	Urethane	Vacuum	Manual Operator	Mounting Bracket	Brass AC/DC	
1/4	1/16	8345P001	-	●	V	-	-	-	-	-	-	-	MO	-	322925
1/4	1/4	EE8551P401*	EE8551P409	●	-	-	-	-	-	-	-	-	MH/MS	-	-
1/4	1/4	8344P070	-	●	V	-	-	-	-	-	-	-	MO	-	322696
3/4	3/4	8344P080	-	●	V	-	-	-	-	-	-	-	MO	-	322700
3/8	3/8	8344P072	-	●	V	-	-	-	-	-	-	-	MO	-	322697
1/2	3/8	8344P074	-	●	V	-	-	-	-	-	-	-	MO	-	322697
3/4	3/4	8344P076	-	●	V	-	-	-	-	-	-	-	MO	-	322698
1	3/4	8344P078	-	●	V	-	-	-	-	-	-	-	MO	-	322698

● = Standard. \* Aluminum body.

### Important

A Minimum Operating Pressure Differential must be maintained between the pressure and exhaust ports. Supply and exhaust piping must be full area, unrestricted. ASCO flow controls and other similar components must be installed in the cylinder lines only.

Dimensions: inches

Const. Ref.	B	C	D	E	F	G	H	I	J	K	Exhaust Pipe Size
1	3.98	3.04	2.09	1.00	1.75	2.06	1.87	3.00	1.09	-	1/4
2	3.98	3.04	2.0	1.12	2.08	2.94	1.87	4.82	1.03	1.41	3/8
3	3.98	3.04	2.0	0.94	2.06	3.18	1.87	6.05	1.50	1.86	1/2
4	3.98	3.04	2.0	1.31	2.86	4.12	1.87	8.25	2.10	2.12	1

Const. Ref. 1

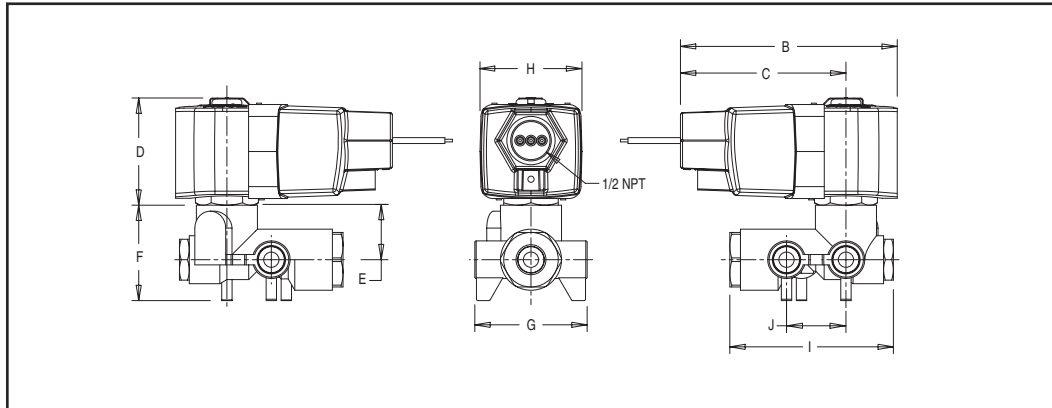

Const. Ref. 2

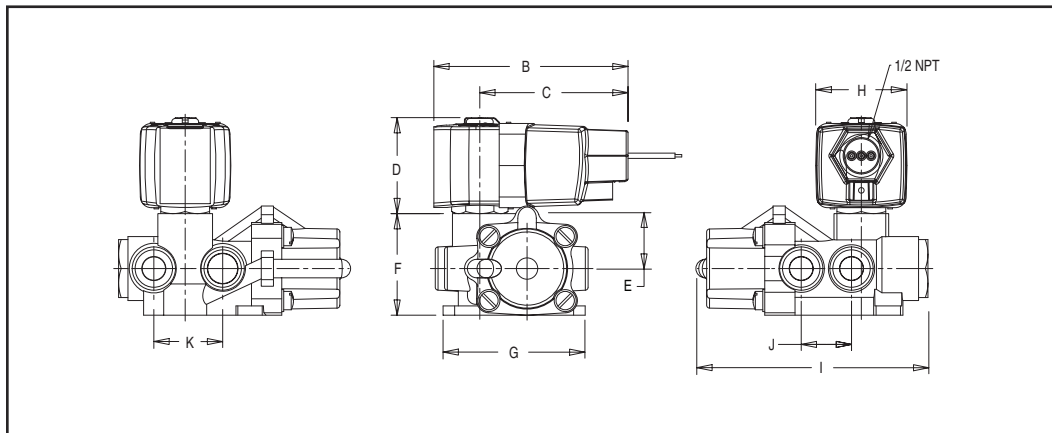

Const. Ref. 3, 4

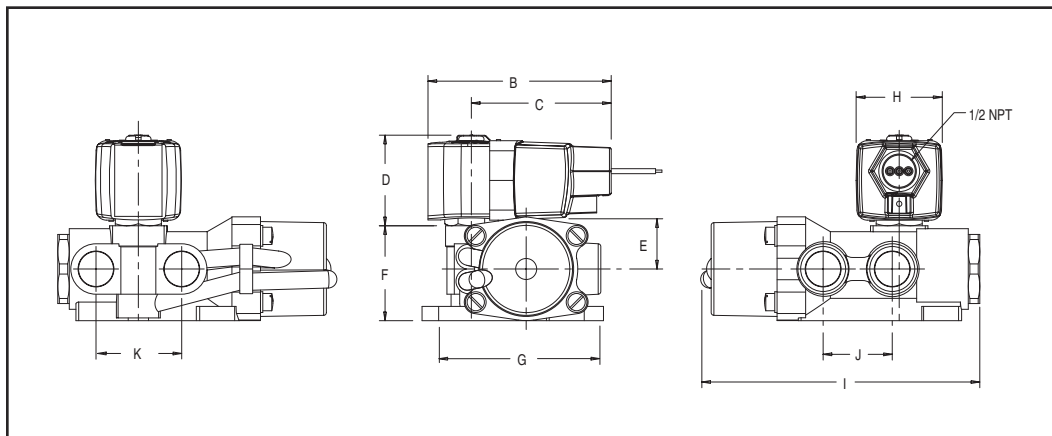



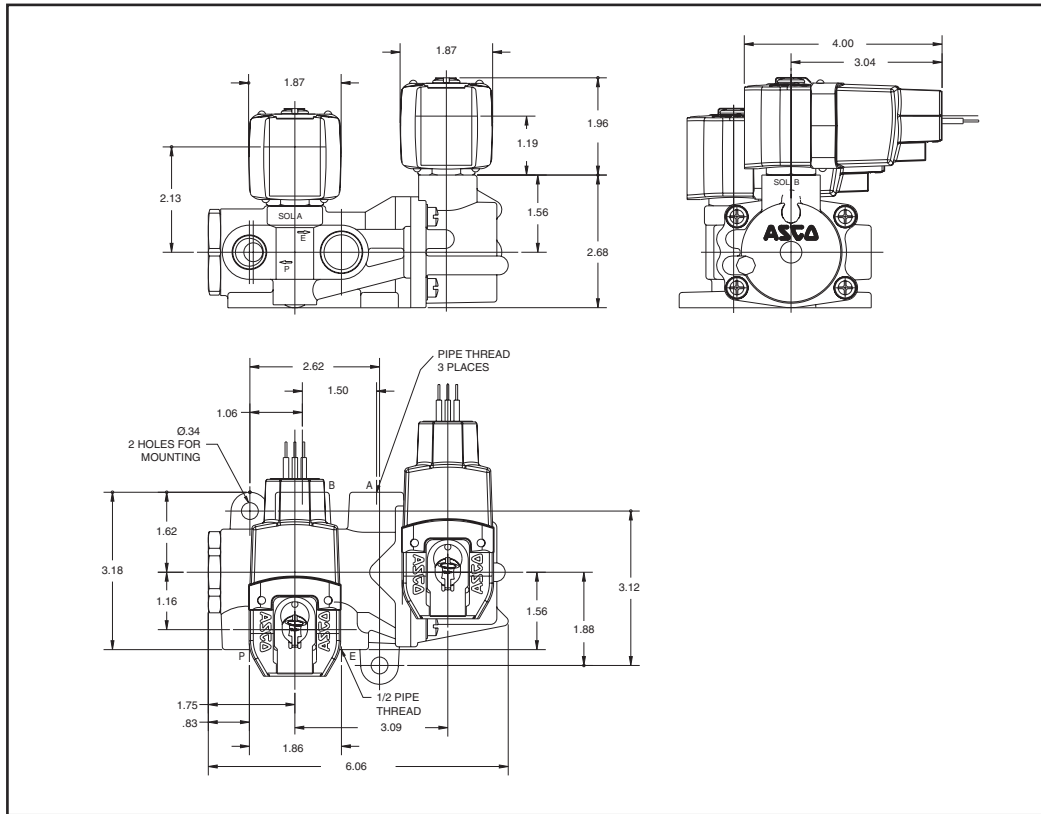

Dimensions: inches

Const. Ref. 5



Const. Ref. 6

Series	8551
NPT	1/4
L1	4.96
H2	3.97
H1	1.08
W	1.77

Optional Manual Operators		
Add Suffix		Description
MO		Push and turn to lock with flat head screwdriver slot
MI		Momentary push in with flat head screwdriver slot
MH		Momentary push in by hand
MS		Push and turn to lock by hand

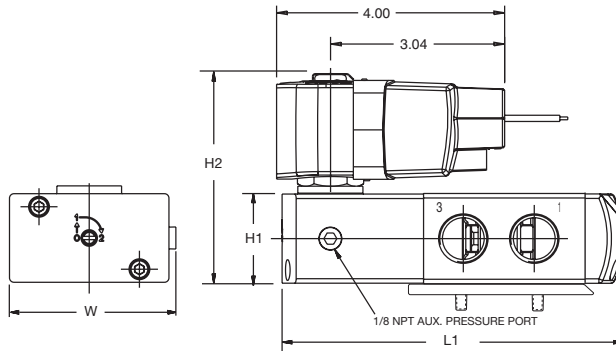

8551 NAMUR Footprint

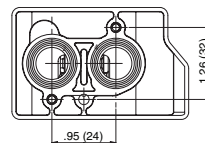



## Engineering Section

### Principles of Operation

A solenoid valve is a combination of two basic functional units:

- A solenoid (electromagnet) with its core.
- A valve body containing one or more orifices.

Flow through an orifice is controlled by the movement of the core when the solenoid is energized or de-energized. The core is enclosed in a sealed tube, providing a compact, leaktight assembly. For additional information on different types and functions of solenoid valves including direct acting, internally pilot operated valves, two-way, three-way, and four-way valves please visit our website at [www.ascovalue.com](http://www.ascovalue.com).

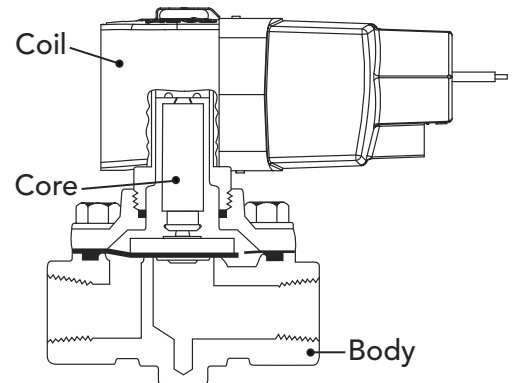

### Solenoids

All RedHat Next Generation solenoid valves are rated for continuous duty under the operating conditions outlined within this section.

### Coil Operating Voltage Ranges

All coils are designed for industrial operating voltages and can be used on the following voltage ranges:

Voltage Range	Minimum Voltage	Maximum Voltage
100-240V/50 or 60Hz/DC	85	264
24-120V/50 or 60Hz/DC	20.4	132
12-24/DC only	10.4	26.4

The coils with voltage ranges of 100-240 and 24-120 have three lead wires, 24 inches long (2 red for power input, and one green lead for grounding where necessary). These two versions are not polarity sensitive.

The coil with a voltage range of 12-24/DC has 3 lead wires, one red, one black, and one green. This coil is polarity sensitive. The red lead is the positive, black is the negative, and green is the ground wire. This solenoid is also polarity protected. Reversing the polarity will not damage the coil, but the coil will not function until the correct polarity is applied.

**Note:** The 100-240 and 24-120 voltage range is also suitable for battery charging circuits designed around a 125/DC nominal voltage range.

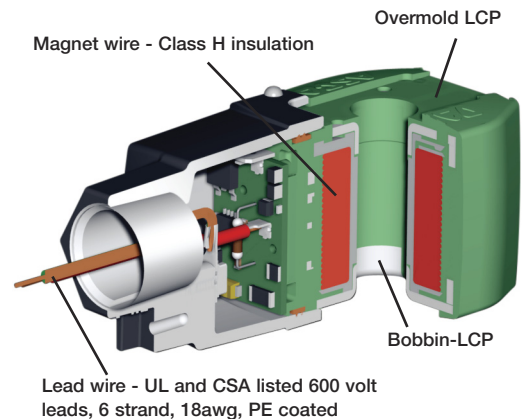

**Electrical Specifications**

2 Watt Electronic Coils	Type
Maximum Ambient Temperature	140°F
Maximum Cycle Rate	1 Operation/ Second
Standard Coil Class of Insulation	H

**Power Consumption**

The Next Generation solenoid nominal power rating is 2 watts. Depending on the input voltage applied, the actual power rating may vary. Please use the charts below to determine your actual power rating.

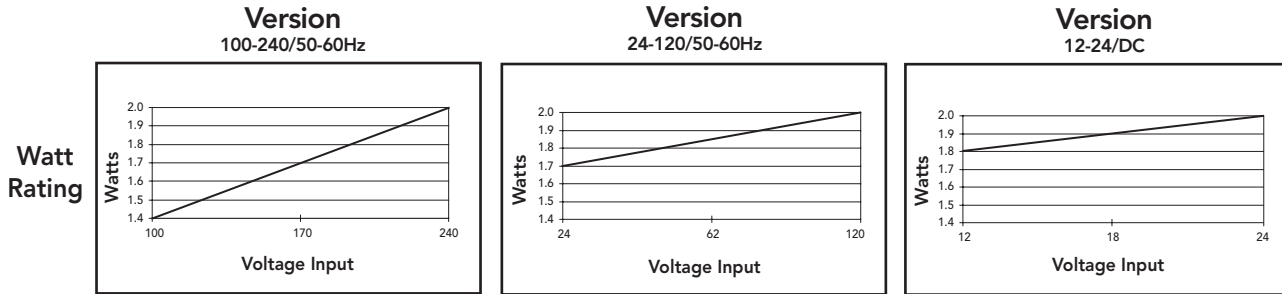

The advanced technology used in the Next Generation coil includes electronic circuitry which may limit the compatibility with certain control system components. The following issues need to be considered when specifying an output card or device to operate the Next Generation coil. An initial inrush current spike is drawn by the Next Generation coil. This inrush spike is 72 msec in duration, which is sufficient time for the core to reach the plugnut. The electrical requirement then drops to the holding value.

**Inrush Current:** The power source, wiring, and output device used need to have surge ratings equal to or greater than the inrush current value (appropriate to the voltage range) specified in the table below.

Inrush Current Rating	
Coil Version	Peak Inrush Current (Amps)
12-24/DC	3.2
24-120/50-60Hz/DC	1.4
100-240/50-60Hz/DC	0.32
Maximum Duration = 72 ms	

**Holding Current:** The power source, wiring, and output device used need to have continuous current ratings equal to or greater than the holding current value (appropriate to the voltage range) specified in the table below.

Holding Current Rating			
Coil Version	Input Voltage	Average Holding Current (Amps)	Average Holding Volt-Amps (VA)
12-24/DC	12	0.340	4.0
	24	0.250	6.0
24-120/50-60Hz/DC	24	0.170	4.0
	120	0.100	10.0
100-240/50-60Hz/DC	100	0.040	4.0
	240	0.032	7.5

**Leakage Currents:** The leakage current is defined as a current that is supplied from an output device when the device is in its off or de-activated state. Operation of Next Generation coil in a system that utilizes supervisory currents is not recommended.

Maximum Leakage Current	3 mA
-------------------------	------

## Solenoid Enclosures

The Next Generation solenoid coil is fully encapsulated using Dupont™ Zenite® Liquid Crystal Polymer resin (LCP). Zenite (LCP) is a thermoplastic polyester resin which exhibits several advantages over other thermoplastics. The advantages include excellent resistance to a wide range of organic solvents and automotive fluids\*, resistance to impact, and long term retention of properties at continuous-use temperatures.

\*Chemical resistance of Zenite LCP may not be suitable for all applications. Zenite LCP is not suitable for caustic solution. Please consult ASCO for appropriate product solutions.

Zenite is a registered Trademarks of E. I. du Pont de Nemours and Company.



**General Purpose/Watertight** – Intended for indoor and outdoor use and provides protection classifications from NEMA types 1 through 4X.

**Type 1 General Purpose** – Intended for indoor use, primarily to provide protection for enclosed parts in locations without unusual service conditions. DIN-type terminals meeting ISO 4400 and DIN Standard 43650.

**Type 2 Dripproof** – Intended for indoor use, primarily to provide protection against limited amounts of falling water or dirt.

**Type 3 Raintight, Dusttight, and Sleet (Ice) Resistant** – Intended for outdoor use, primarily to provide protection against wind-blown dust, rain, and sleet; undamaged by the formation of ice on the enclosure.

**Type 3S Raintight, Dusttight, and Sleet (Ice) Resistant** – Intended for outdoor use, primarily to provide protection against wind-blown dust, rain, and sleet; external mechanism remains operable when ice laden.

**Type 3R Rainproof, Sleet (Ice) Resistant** – Intended for outdoor use, primarily to provide protection against falling rain and sleet; undamaged by the formation of ice on the enclosure.

**Type 4 Watertight and Dusttight** – Intended for indoor or outdoor use to provide protection against splashing water, water seepage, falling or hose-directed water, and severe external condensation; undamaged by the formation of ice on the enclosure.

**Type 4X Watertight, Dusttight, and Corrosion Resistant** – Same as Type 4 but provides additional protection to resist corrosion.

**Class I, Division 2 for Hazardous Locations/Watertight** – Meets Types 1 through 4X and is UL listed and CSA certified for Class I, Division 2, Groups A, B, C, and D and Class II, Division 2, Groups F and G. Operating temperature code T4A (120°C).

## Valve Specifications

### Minimum Operating Pressure Differential

The minimum operating pressure differential is required to fully open the valve and keep it open. For 2-way valves with a floating diaphragm, the valve may start to close below the minimum pressure differential. For 3 and 4-way valves, the minimum operating pressure differential is measured between the pressure and exhaust ports and must be maintained through the operating cycle to ensure complete transfer from one position to the other.

**Note:** Hung diaphragm constructions do not require a minimum pressure differential, however, may not yield maximum flow rates at low-pressure differentials.

### Maximum Operating Pressure Differential (MOPD)

The maximum operating pressure differential refers to the maximum difference in pressure between the inlet and outlet ports, against which the solenoid can safely operate the valve. If the pressure at the outlet is not known, it is safest to regard the supply pressure as the MOPD.

### Minimum Ambient Temperature

The nominal limitation of 32°F (0°C) is advisable for any valve that might contain moisture (water vapor). Where freezing water is not a factor, the minimum ambient temperature of the products listed in this catalog is 14°F (-10°C). For 8262/8263/8314 Series, the minimum ambient temperature is -13°F (-25°C). Special constructions are available with low temperature elastomers to provide service at -40°F (-40°C) ambient temperatures. Consult ASCO for more information.

### Maximum Ambient Temperature

The maximum ambient temperature is 140°F (60°C). This limit is based on continuous energization with the maximum fluid temperatures as shown on each catalog page.

### Response Time

Response time from fully closed to fully open or vice versa depends on valve size, operating mode, fluids, temperature, inlet pressure, and pressure drop. The response times for Next Generation are defined as:

- Small direct acting valves – 10 to 60 msec
- Large direct acting valves – 25 to 90 msec

Internally pilot operated valves:

- Small diaphragm types – 20 to 100 msec
- Large diaphragm types – 80 to 150 msec
- Small piston types – 80 to 150 msec
- Large piston types – 105 to 200 msec

Operation on liquids has relatively little effect on small direct acting valves, however, response times of large direct acting and internally piloted valves may be lengthened by 50% to 100%.

### Viscosity

All valves with a pressure rating for light oil are designed for use with oils rated for a maximum of 300 SSU's with the following exceptions:

- Series 8314, 8317, 8321 – 45 SSU
- Series 8345 – 50 SSU

## Manual Operators

Manual operators are provided to operate the valves manually when electric actuation is not provided. There are two basic types of manual operators, momentary and maintained. To determine which type of manual operator is available for your valves, please see the Optional Features Chart on the relevant valve catalog page. Once it is determined that the subject valve can accommodate a manual operator, the chart below will tell you the type of manual operator. The chart also references the relevant cutaway illustration.

Series Number	Const. Ref.	Manual Operator Suffix	Manual Operator Type	Illustration Number
8030	8	MO	Maintained	3
8210	4, 7, 10, 11, 12	MO	Maintained	2
8262	1	MS	Maintained	6
8263	1	MS	Maintained	6
8314	1	MS	Maintained	6
8316	5, 6	MO	Maintained	2
8320	2	MO	Momentary	1
8320	2	MS	Maintained	6
8321	4	MO	Momentary	1
8321	4	MS	Maintained	3
8344	1, 3, 4	MO	Maintained	2
8345	2	MO	Maintained	5

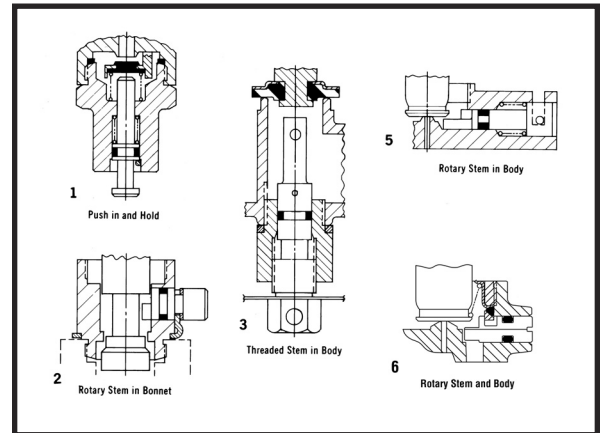

## Resilient Material Selection

**Acetal (POM)** – A high performance engineered plastic with good fatigue life, low moisture sensitivity, and high resistance to solvents and chemicals.

**EPDM (Ethylene Propylene)** – EPDM is selected for applications above the NBR temperature range, such as handling hot water and steam. Ethylene propylene has an extremely wide range of fluid compatibility, but has the distinct disadvantage that it cannot be used with petroleum-based fluids or contaminated fluids (such as lubricated air). It has a useful temperature range of -10°F to 300°F (-23°C to 149°C).

**FKM** – FKM is a fluorocarbon elastomer primarily developed for handling such hydrocarbons as jet fuels, gasolines, solvents, etc., which normally cause detrimental swelling to NBR. FKM has a high temperature range similar to EPDM, but more resistant to “dry heat.” FKM has a wide range of chemical compatibility. It has a useful temperature range of 0°F to 350°F (-18°C to 177°C).

**CR (Chloroprene, Neoprene)** – CR is principally used as an external seal in refrigeration applications. It is also utilized for oxygen service. It has a useful temperature range of 0°F to 180°F (-18°C to 82°C).

**NBR (Buna "N", Nitrile)** – NBR is commonly referred to as a nitrile rubber and is the standard synthetic elastomer for accomplishing resilient-type seating or sealing in ASCO valves. It has excellent compatibility for most air, water, and light oil applications. It has a useful temperature range of 0°F to 180°F (-18°C to 82°C).

**Oxygen Service** – All valve parts are degreased and blacklight inspected for cleanliness. They are assembled and tested in a clean area using oil-free air or nitrogen; helium mass spectrometer tested for external leakage. The pipe connections are sealed with plugs, and each valve is tagged certifying testing. All valves are shipped in sealed bags.

**PTFE** – PTFE and PTFE with fillers are considered more a plastic than a resilient-type material. They are virtually unattacked by any fluid. Their temperature usage has ranges from discs for cryogenic valves to discs for steam valves. They are not easily fabricated and are known to have “cold flow” characteristics which may contribute to objectionable leakage, particularly on gases.

**Urethane** – Urethane is primarily used on high pressure valves, and/or for long life applications, because of its high strength and abrasion resistance. The physical and chemical properties of urethane vary depending on whether the compound is polyester or polyether based. Urethane has a wide range of chemical resistance including alcohols, non-aromatic compounds, ethers, edible fats and oils, hydraulic fluid, and water. It has a useful temperature range of -90°F to 200°F for ethers, and -30°F to 200°F for esters. Polyester based Urethanes in contact with moisture should be limited to a maximum temperature of 140°F.

Valve Parts in Contact with Fluids						
Series	Body	Seals and Discs	Disc Holder	Core Guide	Springs	Shading Coil
8030	Brass	NBR	-	-	302 Stainless Steel	Copper
8210	304 Stainless Steel	NBR	-	-	302 Stainless Steel	Silver
	Brass	NBR	①	-	302 Stainless Steel	Copper
8223	304 Stainless Steel	PTFE, NBR	-	-	302 Stainless Steel	Silver
	Brass	NBR, PA, PTFE	-	-	302 Stainless Steel	Copper
8262 (≤ 750 psi)	304 Stainless Steel	NBR	-	-	302 Stainless Steel	Silver
8262 (> 750 psi)	304 Stainless Steel	UR	-	-	302 Stainless Steel	Silver
8262 (≤ 750 psi)	Brass	NBR	-	-	302 Stainless Steel	Copper
8262 (> 750 psi)	Brass	UR	-	-	302 Stainless Steel	Copper
8262R077	Brass	LT NBR	-	POM	Inconel	Copper
8262R078	Brass	LT NBR	-	POM	Inconel	Copper
8263	304 Stainless Steel	NBR	-	-	302 Stainless Steel	Silver
8263	Brass	NBR	-	-	302 Stainless Steel	Copper
8314	304 Stainless Steel	NBR, FKM	-	POM	302 Stainless Steel	Silver
8314	Brass	NBR, FKM	-	POM	302 Stainless Steel	Copper
8316	Brass	NBR	POM	POM	302, 17-7PH Stainless Steels	Copper
8317	Brass	NBR, FKM, CR	-	POM	302, 17-7PH Stainless Steels	Copper
8320	303 Stainless Steel	NBR	POM	POM	302 Stainless Steel	Silver
8320	Brass	NBR	POM	POM	302 Stainless Steel	Copper
8321	Brass	NBR	POM	POM	302 Stainless Steel	Copper
8344	Brass	NBR	POM	POM	302, 17-7PH Stainless Steels	Copper
8345	Brass	NBR, PA	-	POM	302 Stainless Steel	Copper
8551	316 Stainless Steel	NBR, PA	-	POM	302 Stainless Steel	Copper
8551	Anodized Aluminum	NBR, PA	-	POM	302 Stainless Steel	Copper

Note: All core tubes are 305 stainless steel and all cores and plugnuts are 430F stainless steel. ① 8210P033, 8210P034, and 8210P035 with PA Disc Holder

## Approvals

### Approval Listing Code and Information

UL, CSA, and CE listings are indicated on each series of valves in this catalog. Listing codes and other information follow in this section.

### Agency Valve Classifications and Code Reference

**Solenoid Recognized Components** – Solenoids in this category are intended for use as factory-installed components of equipment where final acceptability must be determined by UL or CSA. ASCO RedHat Next Generation solenoids are listed in the UL recognized component index under Guide No. YSY12 for ordinary locations and VAPT for hazardous locations.

**General Purpose Valves** – Normally open or normally closed valves intended to control the fluid flow, but not to be depended upon to act as safety valves. This is a UL and CSA classification and is not intended to indicate valve service or application. General purpose valves are listed in UL index under Guide No YIOZ or YIOZ2 for ordinary locations and YTSX or YTSX2 for hazardous locations.

**Safety Shutoff Valves** – Normally closed valves of the “on” and “off” type, intended to be actuated by a safety control or emergency device, to prevent unsafe fluid delivery. They may also be used as General Purpose valves. Multiple port valves may be designated as safety shutoff valves only with respect to the normally closed port. This is a UL and CSA classification. Safety shutoff valves are listed in UL index under Guide YIOZ or YIOZ2 for ordinary locations and YTSX or YTSX2 for hazardous locations.

### Underwriters Laboratories (UL)

UL429, “Electrically Operated Valves.”

UL1604, “Electrical Equipment for use in Class I and II, Division 2 and Class III hazardous classified locations.”

### Canadian Standards Association (CSA)

Standard C22.2 No. 139, “Electrically Operated Valves.”

Standard C22.2 No. 213, “Electrical equipment for use in Class I, Division 2 hazardous locations.”

### European Directive (CE)

The council of the European Communities under the treaty establishing the European Economic Community (EEC) adopted into law a series of directives to harmonize technical standards. Solenoid valves may be controlled by:

Council	Directive #
EMC(Electromagnetic Capability)	2004/108/7EC
Low Voltage	206/95/EC
PED(Pressure Equipment Directive)	97/23/EC

ASCO RedHat Next Generation valves comply with these directives as applicable, through third party or self-certification. The General Purpose/Watertight coils each bear the CE approval mark on the coil.



## Quality Assurance

ASCO’s Quality Assurance Program meets all the requirements of ISO9001-2008. ASCO can provide product from 17 ISO-certified facilities around the world.

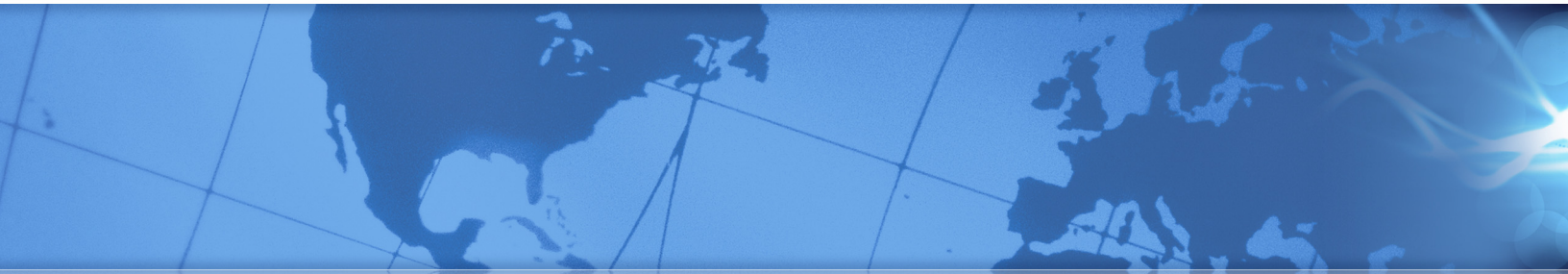

## Global Contacts

### Australia

Tel (61) 2-9-451-7077

### Canada

Tel (1) 519-758-2700

### France

Tel (33) 1-47-14-32-00

### Japan

Tel (81) 798-65-6361

### Singapore

Tel (65) 6556-1100

### Brazil

Tel (55) 11-4208-1700

### China

Tel (86) 21-3395-0000

### Germany

Tel (49)-7237-9960

### Mexico

Tel (52) 55-5809-5640

### United Kingdom

Tel (44) 1695-713600